

RPCT : REPLACEABLE PLASTIC CONICAL TIP



Among the different pick-up material base, SPT offers white Delrin® tips which possess a very low friction coefficient while harder than conventional rubber tips. Delrin is a good material alternative when facing “sticky die” problem. SPT recommends also molded Delrin tips which have the benefit of having smoother geometry transition than machined tips, thus preventing damage to the die surface. The Delrin® tips can be used for temperature up to 130°C.

For smooth and comfortable installation or removal of the RPCT tip on cylindrical stud shank, we recommend to use SPT tight tolerance shank styles.

Tip Configuration	Ø F inch / mm	Ø H inch / mm
RPCT-030	.030 / 0.76	.015 / 0.38
RPCT-040	.040 / 1.02	.020 / 0.51
RPCT-050	.050 / 1.27	.025 / 0.64
RPCT-060	.060 / 1.52	.031 / 0.79
RPCT-070	.070 / 1.78	.035 / 0.89
RPCT-080	.080 / 2.03	.046 / 1.17
RPCT-090	.090 / 2.29	.046 / 1.17

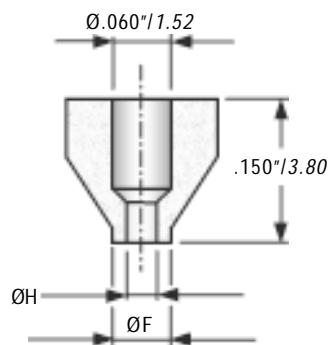

How To Order	
TIP ONLY	Tip Configuration EXAMPLE : RPCT-050
SHANK ONLY	Shank Style & Length L - Shank /Insert Configuration EXAMPLE : 2101 - .315 - RPCT Shank 1059D - RPCT Shank