

NON FINE PITCH: UT SERIES

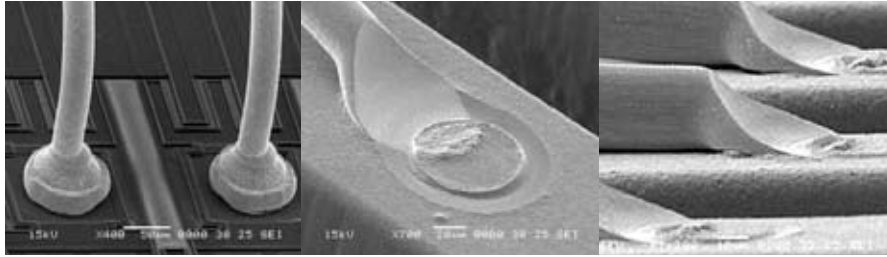

The popular UT series for standard non- fine pitch in- line wire bonding application are available in different face angles of 4° (UTF), 8° (UTS), and 11° (UTE), and a standard 90° chamfer angle with options for 70° and 120°. The UT series is commonly used for discrete packages that doesn't require bottleneck capillary design with its tip diameter ranging from 140µm to 710µm with a standard 30° main taper angle (MTA). Optional 20°MTA is also available. This is a proven capillary, which is designed for higher ball shear, and stitch pull strength readings - mostly for low frequency (<100KHz) wire bonder.

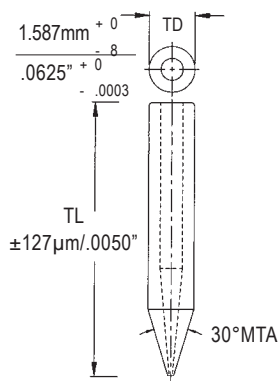

20°MTA available.
Specify at end of part number.

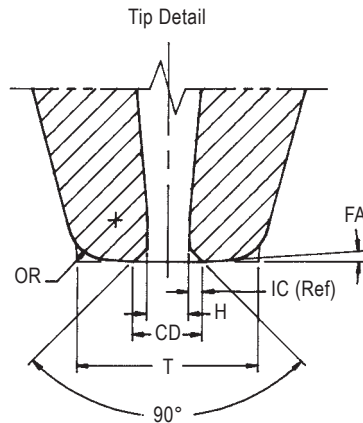

70° and 120° optional chamfer angles are available.
Specify after tip style for alternate angles.
Example : UTF70, UTS120, UTE120

UTF - Face Angle 4°

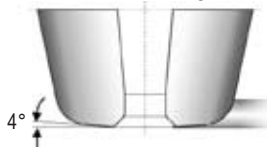

4° face angle provides the most stress concentration on the stitch bond and can be used for lead metalization with poor bondability. (May cause cut stitch on soft metalizations or where there are floating leads).

UTS - Face Angle 8°

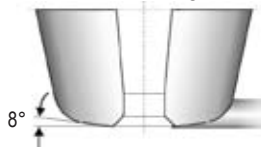

8° face angle commonly used for most applications

UTE - Face Angle 11°

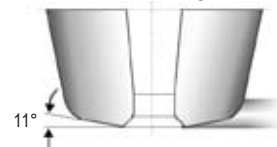

11° face angle is used to prevent "cut stitch" bonds when bonding soft metalizations or bonding on floating leads.

Material + Finish	Tool Diameter (TD)	Tool Length (TL)
C = High density, Fine Grain Ceramic "Polish"	1/16 = 1.587 mm / .0625"	L = 9.53 mm / .375"
CM = High density, Fine Grain Ceramic "Matte"		XL = 11.10 mm / .437"
		XXL = 12.00 mm / .470"
		16mm = .630"
		19mm = .750"

How To Order

SPECIFY : **Tip Style - Material+Finish - Tool Diameter - Tool Length**
(Specify any special modifications required such as Main Taper Angle, MTA)

EXAMPLE : UTF - 38HG - C - 1/16 XL
UTE70 - 33IG - CM - 1/16 L
UTS120 - 43HH - C - 1/16 XL 20MTA

Tip Style			Hole Diameter H µm / in ±3/.0001	Inside Chamfer IC µm / in (Ref)	Chamfer Diameter CD µm / in ±5/.0002	Outside Radius OR µm / in ±8/.0003	Tip Diameter T µm / in ±8/.0003	Useable Wire Diameter µm / in
UTF 4° Face Angle	UTS 8° Face Angle	UTE 11° Face Angle						
UTF - 25FC	UTS - 25FC	UTE - 25FC	25 / .0010	10.5 / .00040	46 / .0018	20 / .0008	140 / .0055	18 / .0007
UTF - 25FF	UTS - 25FF	UTE - 25FF	25 / .0010	19.5 / .00080	64 / .0025	20 / .0008	140 / .0055	18 / .0007
UTF - 30FC	UTS - 30FC	UTE - 30FC	30 / .0012	8.0 / .00030	46 / .0018	20 / .0008	140 / .0055	20 / .0008
UTF - 30FF	UTS - 30FF	UTE - 30FF	30 / .0012	17.0 / .00070	64 / .0025	20 / .0008	140 / .0055	20 / .0008
UTF - 33FF	UTS - 33FF	UTE - 33FF	33 / .0013	15.5 / .00060	64 / .0025	20 / .0008	140 / .0055	20 / .0008
UTF - 38HG	UTS - 38HG	UTE - 38HG	38 / .0015	15.0 / .00059	68 / .0027	38 / .0015	165 / .0065	25 / .0010 - 30 / .0012
UTF - 41HG	UTS - 41HG	UTE - 41HG	41 / .0016	13.5 / .00053	68 / .0027	38 / .0015	165 / .0065	30 / .0012
UTF - 43HG	UTS - 43HG	UTE - 43HG	43 / .0017	12.5 / .00049	68 / .0027	38 / .0015	165 / .0065	33 / .0013
UTF - 38HH	UTS - 38HH	UTE - 38HH	38 / .0015	18.0 / .00071	74 / .0029	38 / .0015	165 / .0065	25 / .0010 - 30 / .0012
UTF - 41HH	UTS - 41HH	UTE - 41HH	41 / .0016	16.5 / .00065	74 / .0029	38 / .0015	165 / .0065	30 / .0012
UTF - 43HH	UTS - 43HH	UTE - 43HH	43 / .0017	15.5 / .00061	74 / .0029	38 / .0015	165 / .0065	33 / .0013
UTF - 38IG	UTS - 38IG	UTE - 38IG	38 / .0015	15.0 / .00059	68 / .0027	38 / .0015	180 / .0071	25 / .0010 - 30 / .0012
UTF - 41IG	UTS - 41IG	UTE - 41IG	41 / .0016	13.5 / .00053	68 / .0027	38 / .0015	180 / .0071	30 / .0012
UTF - 43IG	UTS - 43IG	UTE - 43IG	43 / .0017	12.5 / .00049	68 / .0027	38 / .0015	180 / .0071	33 / .0013
UTF - 46IG	UTS - 46IG	UTE - 46IG	46 / .0018	11.0 / .00043	68 / .0027	38 / .0015	180 / .0071	33 / .0013
UTF - 38IH	UTS - 38IH	UTE - 38IH	38 / .0015	18.0 / .00071	74 / .0029	38 / .0015	180 / .0071	25 / .0010 - 30 / .0012
UTF - 41IH	UTS - 41IH	UTE - 41IH	41 / .0016	16.5 / .00065	74 / .0029	38 / .0015	180 / .0071	30 / .0012
UTF - 43IH	UTS - 43IH	UTE - 43IH	43 / .0017	15.5 / .00061	74 / .0029	38 / .0015	180 / .0071	33 / .0013
UTF - 46IH	UTS - 46IH	UTE - 46IH	46 / .0018	14.0 / .00055	74 / .0029	38 / .0015	180 / .0071	33 / .0013
UTF - 38II	UTS - 38II	UTE - 38II	38 / .0015	20.0 / .00079	78 / .0031	38 / .0015	180 / .0071	25 / .0010 - 30 / .0012
UTF - 41II	UTS - 41II	UTE - 41II	41 / .0016	18.5 / .00073	78 / .0031	38 / .0015	180 / .0071	30 / .0012
UTF - 43II	UTS - 43II	UTE - 43II	43 / .0017	17.5 / .00069	78 / .0031	38 / .0015	180 / .0071	33 / .0013
UTF - 46II	UTS - 46II	UTE - 46II	46 / .0018	16.0 / .00063	78 / .0031	38 / .0015	180 / .0071	33 / .0013
UTF - 38JG	UTS - 38JG	UTE - 38JG	38 / .0015	15.0 / .00059	68 / .0027	51 / .0020	200 / .0079	25 / .0010 - 30 / .0012
UTF - 41JG	UTS - 41JG	UTE - 41JG	41 / .0016	13.5 / .00053	68 / .0027	51 / .0020	200 / .0079	30 / .0012
UTF - 43JG	UTS - 43JG	UTE - 43JG	43 / .0017	12.5 / .00049	68 / .0027	51 / .0020	200 / .0079	33 / .0013
UTF - 46JG	UTS - 46JG	UTE - 46JG	46 / .0018	11.0 / .00043	68 / .0027	51 / .0020	200 / .0079	33 / .0013
UTF - 38JH	UTS - 38JH	UTE - 38JH	38 / .0015	18.0 / .00071	74 / .0029	51 / .0020	200 / .0079	25 / .0010 - 30 / .0012
UTF - 41JH	UTS - 41JH	UTE - 41JH	41 / .0016	16.5 / .00065	74 / .0029	51 / .0020	200 / .0079	30 / .0012
UTF - 43JH	UTS - 43JH	UTE - 43JH	43 / .0017	15.5 / .00061	74 / .0029	51 / .0020	200 / .0079	33 / .0013
UTF - 46JH	UTS - 46JH	UTE - 46JH	46 / .0018	14.0 / .00055	74 / .0029	51 / .0020	200 / .0079	33 / .0013
UTF - 51JH	UTS - 51JH	UTE - 51JH	51 / .0020	12.0 / .00047	74 / .0029	51 / .0020	200 / .0079	38 / .0015
UTF - 38JI	UTS - 38JI	UTE - 38JI	38 / .0015	20.0 / .00079	78 / .0031	51 / .0020	200 / .0079	25 / .0010 - 30 / .0012
UTF - 41JI	UTS - 41JI	UTE - 41JI	41 / .0016	18.5 / .00073	78 / .0031	51 / .0020	200 / .0079	30 / .0012
UTF - 43JI	UTS - 43JI	UTE - 43JI	43 / .0017	17.5 / .00069	78 / .0031	51 / .0020	200 / .0079	33 / .0013
UTF - 46JI	UTS - 46JI	UTE - 46JI	46 / .0018	16.0 / .00063	78 / .0031	51 / .0020	200 / .0079	33 / .0013
UTF - 51JI	UTS - 51JI	UTE - 51JI	51 / .0020	14.0 / .00055	78 / .0031	51 / .0020	200 / .0079	38 / .0015
UTF - 41KI	UTS - 41KI	UTE - 41KI	41 / .0016	18.5 / .00073	78 / .0031	51 / .0020	225 / .0089	30 / .0012
UTF - 43KI	UTS - 43KI	UTE - 43KI	43 / .0017	17.5 / .00069	78 / .0031	51 / .0020	225 / .0089	33 / .0013
UTF - 46KI	UTS - 46KI	UTE - 46KI	46 / .0018	16.0 / .00063	78 / .0031	51 / .0020	225 / .0089	33 / .0013
UTF - 51KI	UTS - 51KI	UTE - 51KI	51 / .0020	14.0 / .00055	78 / .0031	51 / .0020	225 / .0089	38 / .0015
UTF - 41KJ	UTS - 41KJ	UTE - 41KJ	41 / .0016	22.5 / .00089	86 / .0034	51 / .0020	225 / .0089	30 / .0012
UTF - 43KJ	UTS - 43KJ	UTE - 43KJ	43 / .0017	21.5 / .00085	86 / .0034	51 / .0020	225 / .0089	33 / .0013
UTF - 46KJ	UTS - 46KJ	UTE - 46KJ	46 / .0018	20.0 / .00079	86 / .0034	51 / .0020	225 / .0089	33 / .0013
UTF - 51KJ	UTS - 51KJ	UTE - 51KJ	51 / .0020	18.0 / .00071	86 / .0034	51 / .0020	225 / .0089	38 / .0015
UTF - 43KK	UTS - 43KK	UTE - 43KK	43 / .0017	24.5 / .00096	92 / .0036	51 / .0020	225 / .0089	33 / .0013
UTF - 46KK	UTS - 46KK	UTE - 46KK	46 / .0018	23.0 / .00091	92 / .0036	51 / .0020	225 / .0089	33 / .0013
UTF - 51KK	UTS - 51KK	UTE - 51KK	51 / .0020	21.0 / .00083	92 / .0036	51 / .0020	225 / .0089	38 / .0015
UTF - 43LI	UTS - 43LI	UTE - 43LI	43 / .0017	17.5 / .00069	78 / .0031	51 / .0020	250 / .0098	33 / .0013
UTF - 46LI	UTS - 46LI	UTE - 46LI	46 / .0018	16.0 / .00063	78 / .0031	51 / .0020	250 / .0098	33 / .0013
UTF - 51LI	UTS - 51LI	UTE - 51LI	51 / .0020	14.0 / .00055	78 / .0031	51 / .0020	250 / .0098	38 / .0015
UTF - 43LJ	UTS - 43LJ	UTE - 43LJ	43 / .0017	21.5 / .00085	86 / .0034	51 / .0020	250 / .0098	33 / .0013
UTF - 46LJ	UTS - 46LJ	UTE - 46LJ	46 / .0018	20.0 / .00079	86 / .0034	51 / .0020	250 / .0098	33 / .0013
UTF - 51LJ	UTS - 51LJ	UTE - 51LJ	51 / .0020	18.0 / .00071	86 / .0034	51 / .0020	250 / .0098	38 / .0015
UTF - 43LK	UTS - 43LK	UTE - 43LK	43 / .0017	24.5 / .00096	92 / .0036	51 / .0020	250 / .0098	33 / .0013
UTF - 46LK	UTS - 46LK	UTE - 46LK	46 / .0018	23.0 / .00091	92 / .0036	51 / .0020	250 / .0098	33 / .0013
UTF - 51LK	UTS - 51LK	UTE - 51LK	51 / .0020	21.0 / .00083	92 / .0036	51 / .0020	250 / .0098	38 / .0015
UTF - 64MN	UTS - 64MN	UTE - 64MN	64 / .0025	30.0 / .00120	127 / .0050	64 / .0025	300 / .0118	51 / .0020
UTF - 68MN	UTS - 68MN	UTE - 68MN	68 / .0027	28.0 / .00110	127 / .0050	64 / .0025	300 / .0118	51 / .0020
UTF - 75QU	UTS - 75QU	UTE - 75QU	75 / .0030	30.0 / .00120	140 / .0055	64 / .0025	330 / .0130	51 / .0020 - 64 / .0025
UTF - 84RU	UTS - 84RU	UTE - 84RU	84 / .0033	28.0 / .00110	140 / .0055	75 / .0030	360 / .0142	51 / .0020 - 64 / .0025
UTF - 90UU	UTS - 90UU	UTE - 90UU	90 / .0035	25.0 / .00100	140 / .0055	75 / .0030	430 / .0169	51 / .0020 - 64 / .0025
UTF - 100RV	UTS - 100RV	UTE - 100RV	100 / .0039	25.0 / .00100	152 / .0060	75 / .0030	360 / .0142	75 / .0030
UTF - 100SV	UTS - 100SV	UTE - 100SV	100 / .0039	25.0 / .00100	152 / .0060	75 / .0030	410 / .0161	75 / .0030
UTF - 127SW	UTS - 127SW	UTE - 127SW	127 / .0050	33.0 / .00130	193 / .0076	75 / .0030	410 / .0161	100 / .0039
UTF - 178VY	UTS - 178VY	UTE - 178VY	178 / .0070	38.0 / .00150	254 / .0100	127 / .0050	710 / .0279	127 / .0050

NON FINE PITCH SERIES (UT/CSA) - HOW TO ORDER

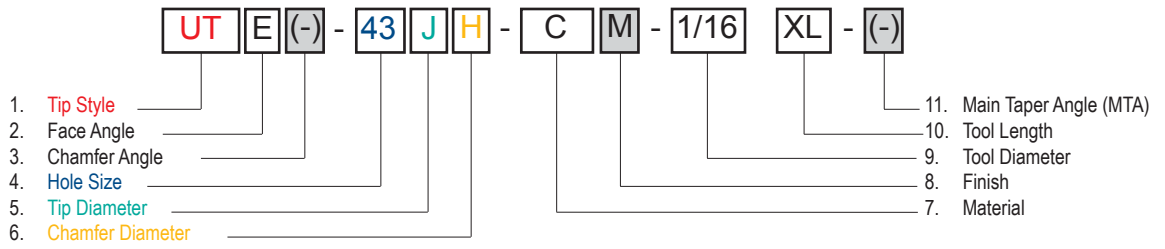

Note : (-) Specify if non-standard

- 1. **Tip Style :** **UT** - Standard capillary with Face Angle for non-Fine Pitch application
CSA - Standard capillary with a 0° Face Angle for non-Fine Pitch application

- 2. **Face Angle :** Z - 0° F - 4° S - 8° E - 11°

- 3. **Chamfer Angle :** Standard - 90° (no need to specify)

4. Hole Size

- 25 µm (.0010")
- 28 µm (.0011")
- 30 µm (.0012")
- 33 µm (.0013")
- 35 µm (.0014")
- 38 µm (.0015")
- 41 µm (.0016")
- 43 µm (.0017")
- 46 µm (.0018")
- 51 µm (.0020")
- 56 µm (.0022")
- 64 µm (.0025")
- 68 µm (.0027")
- 75 µm (.0030")
- 84 µm (.0033")
- 90 µm (.0035")
- 100 µm (.0039")
- 127 µm (.0050")
- 178 µm (.0070")

5. Tip Diameter

- W = 70 µm (.0028")
- Y = 75 µm (.0030")
- Z = 80 µm (.0032")
- A = 90 µm (.0035")
- B = 100 µm (.0039")
- C = 110 µm (.0043")
- D = 120 µm (.0047")
- E = 130 µm (.0051")
- F = 140 µm (.0055")
- G = 150 µm (.0059")
- H = 165 µm (.0065")
- I = 180 µm (.0071")
- J = 200 µm (.0079")
- K = 225 µm (.0089")
- L = 250 µm (.0098")
- M = 300 µm (.0118")
- N = 190 µm (.0075")
- P = 270 µm (.0106")
- Q = 330 µm (.0130")
- R = 360 µm (.0142")
- S = 410 µm (.0161")
- T = 420 µm (.0165")
- U = 430 µm (.0169")
- V = 710 µm (.0279")

6. Chamfer Diameter

- A = 35 µm (.0014")
- B = 41 µm (.0016")
- C = 46 µm (.0018")
- D = 51 µm (.0020")
- E = 58 µm (.0023")
- F = 64 µm (.0025")
- G = 68 µm (.0027")
- H = 74 µm (.0029")
- I = 78 µm (.0031")
- J = 86 µm (.0034")
- K = 92 µm (.0036")
- L = 100 µm (.0039")
- M = 114 µm (.0045")
- N = 127 µm (.0050")
- P = 53 µm (.0021")
- Q = 38 µm (.0015")
- R = 43 µm (.0017")
- S = 48 µm (.0019")
- T = 97 µm (.0038")
- U = 140 µm (.0055")
- V = 152 µm (.0060")
- W = 193 µm (.0076")
- Y = 254 µm (.0100")

- 7. **Material :** C = High Density Fine Grain Ceramic 99.99% AL₂O₃

- 8. **Finish :** Polish - No need to specify
 Matte (M) - Must be specified

- 9. **Tool Diameter :** Standard - 1.587mm (.0625")

- 10. **Tool Length :** L = 9.53 mm (.375") 16mm = .630"
 XL = 11.10 mm (.437") 19mm = .750"
 XXL = 12.0 mm (.470")

11. Main Taper Angle (MTA)

- UT and CSA series - Standard 30° (No need to specify)
- Others - 20° (Must be specified)

NON FINE PITCH SERIES
HOW TO ORDER