

CONCAVE NO-HOLE BONDING TOOLS

1009A STYLE

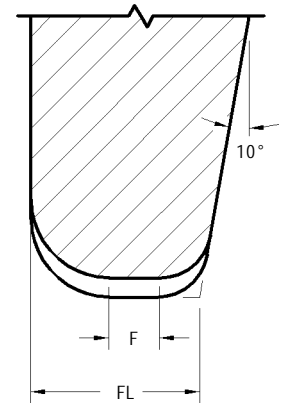
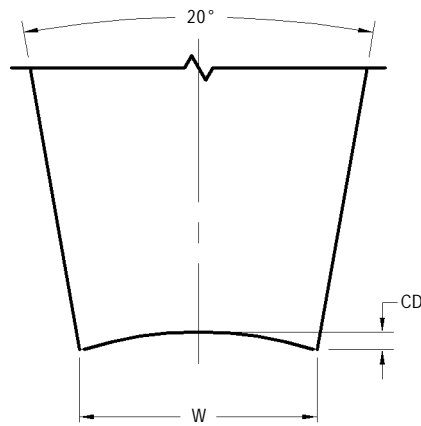
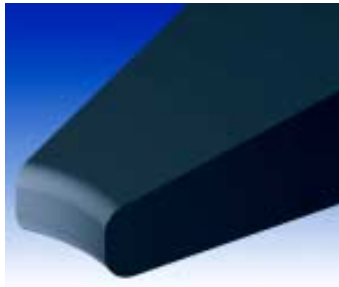

STANDARD DIMENSIONS

Tool Styles - Wire Size	Useable Wire Diameter WD in / μm	Foot Length FL in / μm $\pm .0005/13$	Front Radius FR in / μm $\pm .0005/13$	Back Radius BR in / μm $\pm .0003/8$	Flat F in / μm (Ref)	Foot Width W in / μm $\pm .0005/13$	Concave Depth CD in / μm $\pm .0002/5$
1009A-4	.0040 / 100	.0160 / 406	.0080 / 203	.0050 / 127	.0055 / 140	.0120 / 305	.0010 / 25
1009A-5	.0050 / 125	.0180 / 457	.0090 / 229	.0050 / 127	.0070 / 178	.0150 / 381	.0013 / 33
1009A-6	.0060 / 150	.0180 / 457	.0090 / 229	.0060 / 152	.0065 / 165	.0180 / 457	.0016 / 41
1009A-7	.0070 / 175	.0180 / 457	.0090 / 229	.0060 / 152	.0065 / 165	.0210 / 533	.0018 / 46
1009A-8	.0080 / 200	.0180 / 457	.0090 / 229	.0060 / 152	.0065 / 165	.0240 / 610	.0020 / 51

CONCAVE NO HOLE TOOLS - GENERAL GUIDELINES ON HOW TO ORDER

STYLE	WIRE SIZE	MATERIAL
1009A : Concave No-Hole	Specify Wire Size	W : Tungsten Carbide Ultra Fine Grain for Aluminum Wire

Tool Dia	TD in / mm ±.0001"/3µm	TDF in / mm ±.0005"/13µm	Specified Length	TL in / mm ±.005"/130µm
1/16	.0624 / 1.585	.0570 / 1.448 *	L	.828 / 21.0
1/8	.1249 / 3.172	.0937 / 2.378 ***	1.00	1.000 / 25.4
2mm	.0785 / 1.995 @	.0630 / 1.600 *	20mm	.787 / 20.0
3mm	.1180 / 2.997	.0985 / 2.502 **	29mm	1.142 / 29.0

NOTE	
*	limited size availability.
**	.110" / 2.79mm TDF supplied if required by foot geometry.
***	.1180" / 3.00mm TDF supplied if required by foot geometry.
@	Tolerance +0 / - .0002" / 5µm

FOOT OPTIONS	
C	The FR and BR are polished and a fine matte finish is within the area of the groove. (Standard)
CM	The FR, BR and groove have a matte finish

HOW TO ORDER	
SPECIFY	Style - Wire - Material - Tool Diameter - Tool Length - Foot Option (For modifications to standard tools, use part number and specify modified dimensions or contact our technical support staff for assistance with your requirements). For Shank Style refer to page 62.
EXAMPLE	1009A - 5 - W - 3mm - L - CM 1009A - 8 - W - 1/8 - L - C