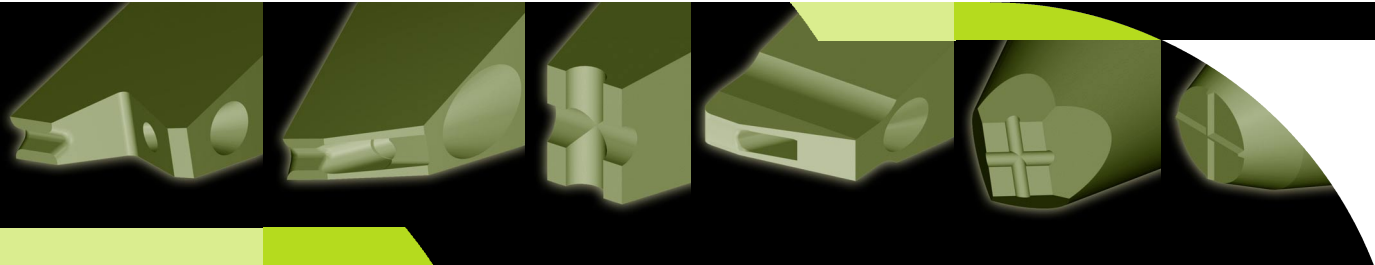


Gold & Aluminum Bonding Wedges



Bonding Spectrum

Global Vision . Worldwide Network . Local Presence .

The SPT Roth Group's strategy centers on developing the Company into an integrated global corporation. Over the last twenty years, we have built on our global vision and invested in building manufacturing and sales facilities strategically around the world to be close to our customers.

The worldwide network combined with excellent logistic facilities ensures prompt and full compliance with customer requirements including ship-to-stock or just-in-time delivery programs. Dedicated and highly qualified sales and service engineers and application specialists ensure that customers receive professional service and support at all times from the design phase to starting mass production.

SPT is open around the world, round the clock.



Pioneer . World Leader .

Small Precision Tools - SPT - is the pioneer and leader of semiconductor bonding tools for over three decades.

SPT is the only bonding tool manufacturer internationally established with marketing and production centres strategically positioned all over the globe, to be close to our customers.



1890
ROTH Group
Lyss, Switzerland



1964
Aprova Ltd.
Lyss, Switzerland



1974
Small Precision Tools Inc.
California, USA



1979
SPT Asia Pte Ltd.
Singapore



1982
Moldinject, Perfectamould AG.
Lyss, Switzerland



1991
Small Precision Tools (Phils.) Inc.
Manila, Philippines



1995
Small Precision Tools Co. Ltd.
Wuxi, China



2001
SPT Japan K.K.
Yokohama, Japan

Creative Solutions . Research & Development . Customer Partnership .

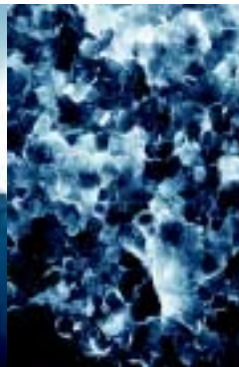
Customer partnership is our belief. At SPT, we listen to our customers. Because, every customer's needs are different, every solution is uniquely designed to satisfy those needs in the most effective way.

SPT offers a wide range of proactive support and services such as consulting, design, analysis, training seminars and benchmarking partnerships. SPT's material and process technology laboratories in Switzerland and Singapore offer technical support and services such as material analysis, process evaluation and characterization and tool design optimization.

Research



Development



Design



Partnership



Quality . Product & Service Excellence .

SPT is committed to quality and customer care. Our commitment to product excellence and continued support of our customers is part of the sustaining culture of SPT.

SPT's partnership philosophy has earned numerous prestigious awards and recognition from our customers.



Evaluation

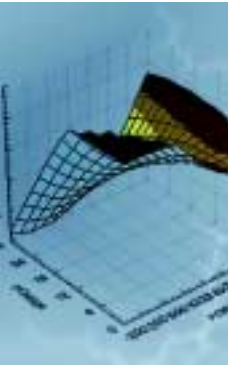
Optimization

Precision

Technology

Training

Excellence



Product Technology . Excellence . Unsurpassed .

SPT positions itself as a progressive high-technology tool manufacturer using state-of-the-art processes. Our production capabilities range from conventional to CNC machining including milling, turning, surface grinding, honing, Electro-Discharge Machining or EDM, jig grinding and more. Our exclusive Injection Molding technology of small complex parts through SPT's own in-house formulation and sintering assures customers of the highest quality in high alumina ceramic and carbide materials.

Our equipment and manufacturing techniques are the most advanced in the ultra precision tool industry.

We make standard and custom designs for specific customer requirements. All tools meet the high precision dimensional and quality standards maintained by Small Precision Tools.

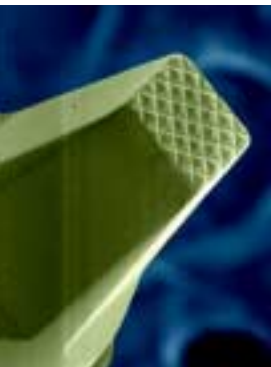
Bonding Capillary

μ BGA Tab Tool

Fine Pitch Bonding Wedge



Waffle Tab Tool



Die Attach Collets



Bushings



Precision Parts



CIM & MIM Parts

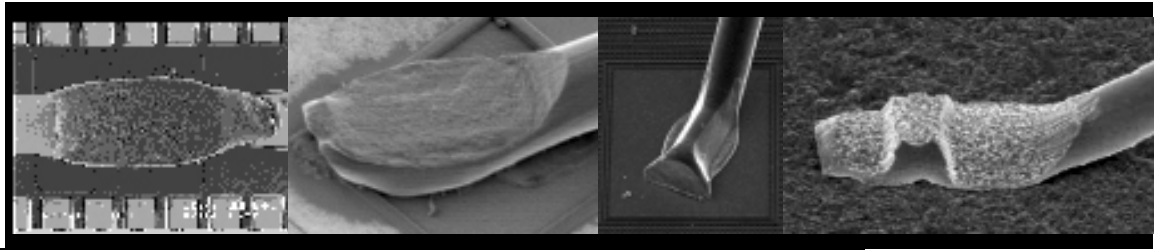


Watch Gear



CONTENTS

	Introduction	
	1 Technology Overview	
	The Wedge Bonding Process	
	2 Basic Ultrasonic Wedge Bonding Process	
	4 Wire Bonding Guide	
	4 Destructive bond pull test	
	5 Non-destructive bond pull test	
	6 Bonding Failures	
	Small Wire Bonding Tools	
	8 Fine Pitch Bonding Tool FP	
	10 Universal Bonding Tool UT / US	
	12 Chip-On-Board Autobonding Tool UT	
	14 Autobonding Tool ABT	
	16 Microwave Bonding Tools M30A / M45A / M55A / M60A / M30B / M45B / M55B / M60B	
	18 Standard Bonding Tools 1001A / 1002A / 1110A / 1001B / 1002B / 1110B	
	20 Slimline Bonding Tools 1200A / 1300A / 1400A / 1100A / 1200B / 1300B / 1400B / 1100B	
	22 Special Bonding Tools 1008A	
	24 Special Bonding Tools XGR	
	26 PF Needles PF20	
	28 Ribbon Wire Bonding Tools RW30 / RW45 / RW55 / RW60	
	Large Wire Bonding Tools	
	30 Large Wire Bonding	
	32 Inline Groove No-hole Bonding Tools OSG7	
	34 Inline Groove No-hole Bonding Tools CKVD	
	36 Inline Groove No-hole Bonding Tools CK	
	38 Inline Groove No-hole Bonding Tools 45CK	
	40 Inline Groove No-hole Bonding Tools LWD6	
	42 Concave No-hole Bonding Tools 1009A	
	44 Inline Groove Notch Tools 3016 / 4516	
	46 Inline Groove Notch Tools 1015A / 1016A / 2015A / 2016A	
	48 Inline Groove Notch Tools 30D6 / 45D6	
	50 Inline Groove Autobonding Tools AB16	
	Single Point Tab Bonding Tools	
	52 Single Point Tab Bonding Tools	
	54 Double Cross Groove 7000 / 7100	
	56 Double Cross Protrusion 7500 / 7600	
	58 Waffle Foot 7045W / 7145W	
	60 Waffle Foot – Shank Flats 7045W / 7145W	
	Small / Large Wire Shank Styles	
	61 Small Wire Shank Style V Style / J Style / H Style / P Style / Standard Style / 180Deg-Rev	
	62 Large Wire Shank Style	
	63 Tip to Shank Ratios	
	64 Tool Selection Guide	
	67 Wedges Requirement Checklist	
The Wire Bonding Process		
Small Wire Bonding Tools		
Large Wire Bonding Tools		
Single Point Tab Bonding Tools		
Small / Large Wire Shank Styles		

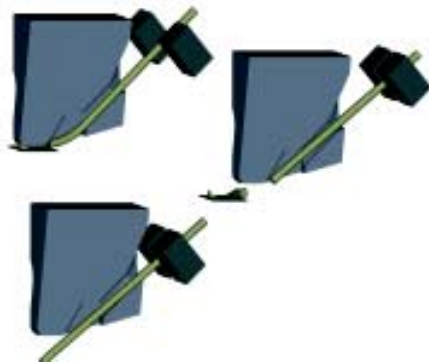


Ultrasonic wedge bonding (SM & LW wire).

The most commonly used method of connecting semiconductor devices to the 'outside' world is via gold or aluminum wire, ranging from .0005"/13 μ m to .003"/76 μ m for Au wire and .0008"/20 μ m to .020"/508 μ m for Al wire. The tip of the wedge vibrates parallel to the bonding wire. The weld is created by deforming the wire at a low temperature in which the energy for the weld formation is supplied from an ultrasonic transducer vibrating (60 to 120 kHz) the bonding tool or wedge. Aluminum wires are connected ultrasonically, gold wires using thermosonic welding (combination of heat 150° - 250°C and ultrasonic energy).

BASIC ULTRASONIC WEDGE BONDING PROCESS

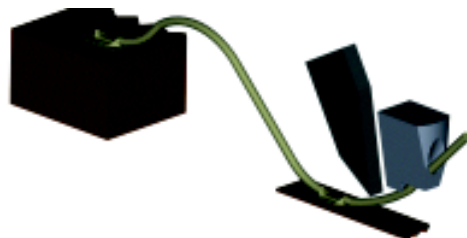
The ultrasonic bonding process typically started by feeding the wire at an angle usually 30-60° from the horizontal bonding surface through a hole in the back of a bonding wedge. Normally, forward bonding is preferred, i.e. the first bond is made to the die and the second is made to the substrate. The reason is that it can be far less susceptible to edge shorts between the wire and die. By descending the wedge onto the IC bond pad, the wire is pinned against the pad surface and an U/S or T/S bond is performed. Next, the wedge rises and executes a motion to create a desired loop shape. At the second bond location, the wedge descends, making a second bond. During the loop formation, the movement of the axis of the bonding wedge feed hole must be aligned with the center line of the first bond, so that the wire can be fed freely through the hole in the wedge. Several methods can be used to end the wire after the second bond. For small wires (<.003"/76µm), clamps can be used to break the wire while machine bonding force is maintained on the second bond (clamp tear), or the clamps remain stationary and the bonding tool raises off the second bond to tear the wire (table tear). The clamp tear process offers a slightly higher yield and reliability than the table tear process due to the force maintained on the second bond during the clamp tear motion. The clamp tear process also offers a slight speed advantage over the table tear process due to fewer required table motions. However, the table tear process, has a higher wire feed angle capability and stationary clamp, has the potential to provide slightly more clearance from package obstructions such as a bond shelf or pin grid. For large bonding wires (>.003"/76µm), the most common method is using a cutter blade. Once the wire is terminated, the wedge ascends. The clamped wire is fed under it to begin bonding the next wire...this process will repeat until the wire bond program is complete.



Clamp tear

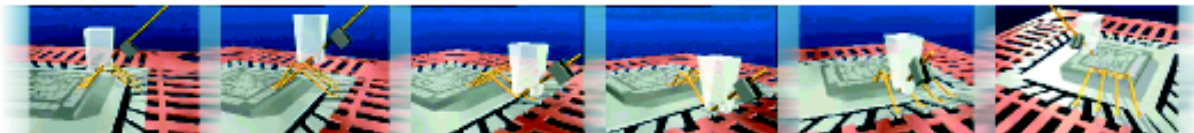


Table tear



Guillotine termination methods

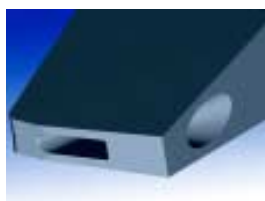
Wedge bonding technique can be used for both aluminum wire and gold wire bonding applications with some slight modification to the back radius to compensate for the lower tensile strength of gold wire. The principle difference between the two processes is that the aluminum wire is bonded in an ultrasonic bonding process at room temperature, whereas gold wire wedge bonding is performed through a thermosonic bonding process with heat up to 175°C. A considerable advantage of the wedge bonding is that it can be designed and manufactured to very small dimensions, down to 50µm pitch. Aluminum ultrasonic bonding is the most common wedge bonding process because of the low cost and can be bonded at room temperature. The main advantage for gold wire wedge bonding is the possibility of avoiding the need for hermetic packaging after bonding due to the inert properties of the gold. In addition, a wedge bond will give a smaller footprint than a ball bond, which specially benefits the microwave devices with small pads that require a gold wire junction down to .0005"/ 13µm.



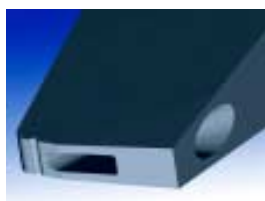
BONDING WEDGE TOOLS

Wedge bonding is performed using a wedge-shaped bonding tool. The wire in wedge bonding is addressed at an angle (30° to 60°) through the rear of the wedge. When special clearance is necessary the wire will be fed at 90° through a hole in the shank for maximum clearance. Low angle wire feed style gives best placement control and tail consistency under the bond foot. High angle wire feed is only used when absolutely necessary due to high package walls where the bonding to the edge of the die is necessary. Tail control and bond placement accuracy is less consistent due to the steep feed angle which causes the wire tail to contact the pad prematurely causing the wire to shift away from underneath the bonding tip or be pushed back into the feed hole. Unlike at lower feed angles (30° to 45°) the wire is in line with the tip. Foot profile of the wedge can be either flat or concave. Most of the automatic aluminum wire applications use the concave foot to reduce wire positioning errors. The flat foot is used mainly with gold wire or with aluminum wire to obtain extremely short bonds. A groove foot has been designed for gold wire wedge bonding to improve the wedge-to-wire gripping. The material used for the wedge is dependent on the bonding wire material. For aluminum wire, the wedge is made of tungsten carbide. For gold wire, the material used is titanium carbide or cermet tip. The cermet tip wedge is most commonly used in applications where low temperature Au to Au bonding is required.

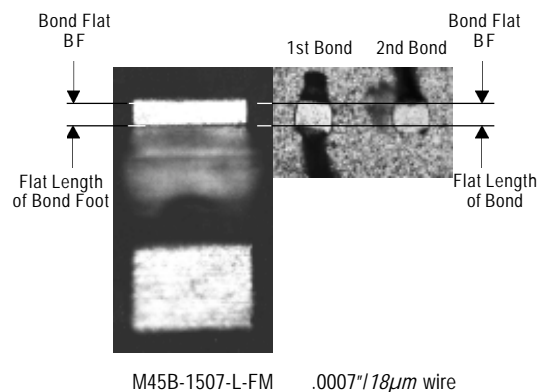
The parameters of the wedge can greatly affect the wire-bond characteristics. For the first bond, pull strength is affected by back radius (BR), bond location is influenced by hole size (H) and tail length is controlled by feed angle, hole shape and surface quality. The main wedge parameters that affect looping are hole size and shape, as well as feed angle. For the second bond, pull strength is defined mainly by front radius (FR), bond length and tail consistency is affected by back radius (BR).



Wedge for Al wire wedge bonding



Wedge for Au wedge bonding



Another major feature of ultrasonic wedges is the Bond Flat (BF). The Bond Flat is defined as the length of the bonding tool foot that appears flat when measuring with a microscope at 300X will give a very close approximation to the actual bond length achieved during the bond process.

PROCESS DEVELOPMENT AND OPTIMIZATION:

The key stages generally include initial process design and development, process characterization, process control and process optimization. These stages form a continuous loop between characterization and control with periodic optimization and development.

In the initial stages of the process, process capabilities should be known to set achievable goals. The second stage (process characterization) is to collect and categorize the data on wire-bonding failures such as bond off center, bond not sticking on die, wire breaking and so on. Process control (the third stage) is important for a successful process. To achieve a stable performance, the operating variables such as bond program parameters, machine setup, operation procedures, bonding tool installation, wire pull procedures and product change must be minimized and consistent across the process, such as in the training of operators must be established. If the previous stages of process development are in place, process optimization can be performed. Once a process is operating in a production environment, statistical process control (SPC) can be applied to such items as destructive wire pull and non-destructive wire pull (commonly used in military products and large wire-bonding applications) to monitor the process and to minimize process drift.

BOND EVALUATION:

After bonding, the wire-bond can be evaluated with visual and mechanical testing. Depending on the customer requirements, the following are the three most common mechanical testing methods that are employed for the evaluation of bond strength.

1. Destructive bond pull test
2. Non-destructive bond pull test (most commonly used in military and automotive products)
3. Bond shear test (commonly used in wire dia. $>.004"/100\mu\text{m}$)

Destructive Bond Pull Test:

Destructive pull test, i.e. bond pull strength test, is the primary method to evaluate the bond strength by hooking and pulling the bonded wire until failure occurs. The purpose of this test is to examine the bond strength and to certify the proper setup of the bonding machine parameters. The results are important evidences for evaluating bonding quality and reliability. The same results evaluate the understanding of bond failure mechanisms including bond pad cratering, over-bonding and shear fatigue at bonded interfaces during temperature cycling. Pull strength is strongly dependent upon the geometrical configuration of the pull test.



Schematic of destructive pull test

The failure during pull test may occur at one of the five positions in the wire-bond structure:

- A. Lift off first bond
- B. Wire break at transition first bond
- C. Wire break mid span
- D. Wire break at transition second bond
- E. Lift off second bond

When the process is in control, the bond should fail at B or D. If failures occur at A, C, or E, then the bonding parameters, metallization, bonding machine, bonding tool, bonding wire and wire pull hook all have to be reviewed.

Non-Destructive Bond Pull Test:

This test is a variation of the destructive pull test in that the maximum force applied to the bond loop is limited to a predetermined value. It is usually used to detect unacceptable wire-bonds while avoiding damage to acceptable wire-bonds. The most common failures are bond lifts, tight wires, heel cracks and cratering. The non-destructive pull test force is specified for a given wire diameter and metallurgy.



Schematic of non-destructive pull test

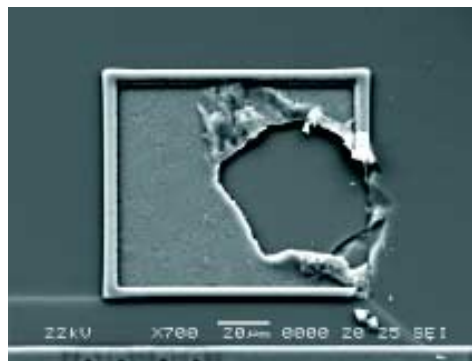
FAILURE MECHANISMS OF WIRE-BONDS:

A major advantage of wire-bonding for microelectronic interconnection is its solid base of reliability from bond strength studies to time and temperature design factors. Many factors may degrade yield and reliability of the wire-bonds. Trouble shooting can be carried out using a “fishbone diagram” to isolate the errors in wire-bonding process. It is then possible to focus problem-solving effort on fewer aspects of the process.

CRATERING OF A WIRE-BOND PAD:

Cratering, typically occurring in ultrasonic bonding, is defined as damage to the semiconductor glass or other layers that lie under the bonding pad metallization. The damage may be in the form of a recognizable divot but more commonly takes the form of invisible structural damage. This damage can degrade the device characteristics and is often taken for electrical damage. Main causes of cratering are often targeted to the tool design but in most cases is related to the following:

- High ultrasonic energy can cause stacking faults to occur in the silicon lattice.
- Too low bond force can induce cratering in wedge bonds causing the tool to bounce/vibrate when the power and time is applied.
- Excessive tool-to-substrate impact velocity does not induce cratering in silicon but does on weaker crystals such as gallium arsenide.
- Too short of a tail can make the face of the bonding tool contact the metallization.
- Heavy probing may lead to chip damage under the influence of the applied ultrasonics.
- Best bonds are made when the pad and wire hardness match which is the optimum condition for minimum cratering.
- Harder wire can cause silicon craters during aluminum ultrasonic bonding.



Cratering

WIRE-BOND FRACTURE AND LIFT-OFF:

The heel of the bond is already overworked (weakened) during ultrasonic welding and flexing forward and backward is often sufficient to form a crack. Metallurgical crack formation is a critical issue for wire-bonding process. The crack often forms in the heel of the first bond of aluminum wedge bonding. The following reasons can cause heel cracks:

- Using a sharp heeled bonding tool.
- Operator motion of the pedestal (if a manual bonder is used).
- Excessive bond deformation.
- Rapid-tool movement after first bond.

High loops can lead to greater tool motion and an increased probability of heel cracking. The cracks can be enhanced when the second bond is significantly lower than the first, typical of reverse bonding since the wire is bend backwards more than if bonds are on the same level. Heel cracking can reduce pull strengths by up to 40% and can also lead to premature cycling failures. An enhancement feature that can be added to the Back Radius to minimize heel cracks is the Chamfered Back Radius (CBR), a common design feature recommended only when heel cracks are a problem. Overcompensation in the removal or prevention of heel cracks may cause inconsistencies in wire termination which can result in 'missing wire' and inconsistent tail length problems.



SEM of Bond with Cracked Heel

CBR Wedge Profile

Heel Crack & CBR Wedge Profile

INCONSISTENT TAILS:

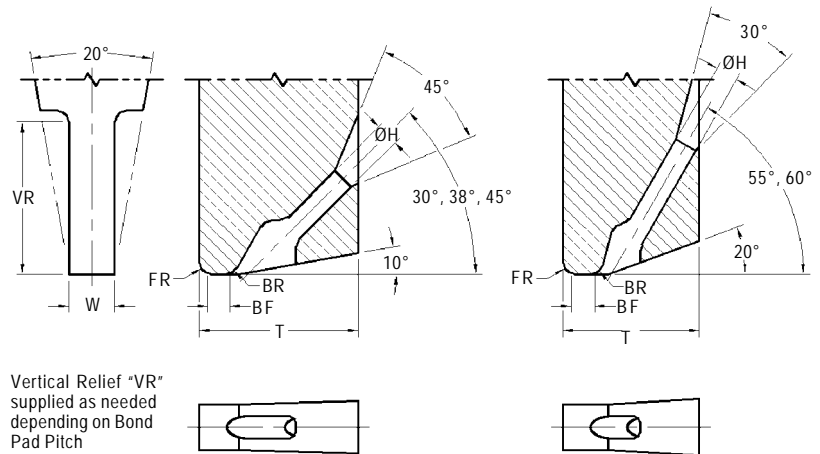
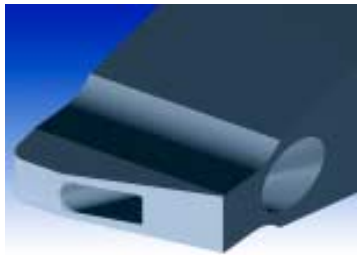
This is the most common problem encountered in wedge bonding and one of the most difficult to cure as it can be caused by any of the following:

- Dirty wire path
- Incorrect wire feed angle
- Partially blocked wedge
- Dirty wire clamps
- Incorrect clamp gap
- Incorrect clamp force
- Faulty feed/tear mechanism
- Incorrect wire tension
- Incorrect radii (to large)

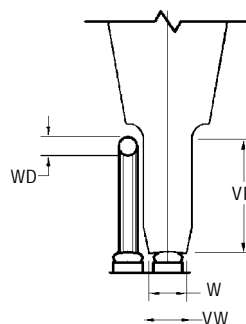
Too short a tail means that the force on the resulting first bond is distributed over a much smaller area leading to excessive deformation. Too long a tail may lead to shorting between pads.

FP SERIES - FINE PITCH BONDING TOOL

There are a number of technical challenges unique to fine pitch wire-bond process. It includes a broad mix of component technologies. A typical package may contain 200 different components ranging in size from (.008 inch X .008 inch) and .004 inches thick to (.500 inch X .500 inch). The sheer number of different sized chips and tight chip-to-chip spacing create problems in accessing the bond pads. Fine pitch wire-bonding is of particular importance in the manufacturing of these devices. Fine pitch is defined as 100 microns or less center-to-center distances between bond pads. Many devices use the latest high performance chips that typically include 4 mil pitch bond pads. Innovations in tool configurations, machine vision systems and wire-bonding ultrasonics have been critical to improved fine pitch wedge bonding



STANDARD DIMENSIONS									
Tool Styles	Wire Feed Angle	Hole / Bond Flat	Hole H in / μm $\pm .00015/3.8$	Bond Flat BF in / μm $\pm .00015/3.8$	Foot Width W in / μm $\pm .0002/5$	Tip Thickness T 30° in / μm $\pm .0005/13$	Tip Thickness T 38°/45° in / μm $\pm .0005/13$	Tip Thickness T 55°/60° in / μm $\pm .0005/13$	Useable Wire Diameter in / μm
FP30	30°	1507	.0015 / 38	.0007 / 18	.0030 / 76	.0140 / 356	.0140 / 356	.0120 / 305	.0005 / 13 through .0008 / 20
		1510	.0015 / 38	.0010 / 25	.0030 / 76	.0140 / 356	.0140 / 356	.0120 / 305	
		1515	.0015 / 38	.0015 / 38	.0030 / 76	.0140 / 356	.0140 / 356	.0120 / 305	
		1520	.0015 / 38	.0020 / 51	.0030 / 76	.0140 / 356	.0140 / 356	.0120 / 305	
FP38	38°	2010	.0020 / 51	.0010 / 25	.0030 / 76	.0150 / 381	.0140 / 356	.0140 / 356	.0008 / 20 through .0010 / 25
		2015	.0020 / 51	.0015 / 38	.0030 / 76	.0150 / 381	.0140 / 356	.0140 / 356	
FP45	45°	2020	.0020 / 51	.0020 / 51	.0030 / 76	.0150 / 381	.0140 / 356	.0140 / 356	.0010 / 25 through .0013 / 33
		2025	.0020 / 51	.0025 / 64	.0030 / 76	.0190 / 483	.0140 / 356	.0140 / 356	
FP55	55°	2520	.0025 / 64	.0020 / 51	.0040 / 102	.0190 / 483	.0140 / 356	.0140 / 356	.0015 / 38 through .0020 / 51
		2525	.0025 / 64	.0025 / 64	.0040 / 102	.0190 / 483	.0140 / 356	.0140 / 356	
FP60	60°	2530	.0025 / 64	.0030 / 76	.0040 / 102	.0190 / 483	.0140 / 356	.0140 / 356	.0015 / 38 through .0020 / 51
		3025	.0030 / 76	.0025 / 64	.0040 / 102	.0200 / 508	.0190 / 483	.0170 / 432	
		3030	.0030 / 76	.0030 / 76	.0040 / 102	.0200 / 508	.0190 / 483	.0170 / 432	
		3035	.0030 / 76	.0035 / 89	.0040 / 102	.0200 / 508	.0190 / 483	.0170 / 432	.0020 / 51



VR Set "A" 70 μm to 80 μm BPP
W = .0030", VW = .0040", VR = .0060"

VR Set "B" 60 μm to 70 μm BPP
W = .0025", VW = .0030", VR = .0060"

VR Set "C" 50 μm to 60 μm BPP
W = .0020", VW = .0025", VR = .0060"
Max HW = .0015", for WD = .0010" or less
Oval Hole

FP SERIES - GENERAL GUIDELINES ON HOW TO ORDER

STYLE	FEED ANGLE
FP = Fine Pitch Standard Design	30°, 38°, 45°, 55°, 60°

RADIUS SET	Wire Material	Wire Diameter	Hole Size	FR ± .0001/3	BR ± .0001/3
A	Aluminum / Gold	.0010 / 25 - .0015 / 38	.0015 / 38 - .0030 / 76	.0010 / 25	.0010 / 25
B	Gold	.0010 / 25 - .0015 / 38	.0015 / 38 - .0030 / 76	.0010 / 25	.0006 / 15
B	Aluminum	.0007 / 18 - .0010 / 25	.0015 / 38 - .0020 / 51	.0010 / 25	.0006 / 15
C	Gold	.0005 / 13 - .0010 / 25	.0015 / 38 - .0020 / 51	.0004 / 10	.0004 / 10

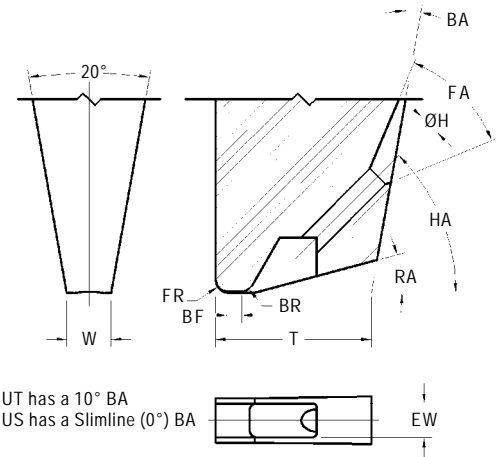
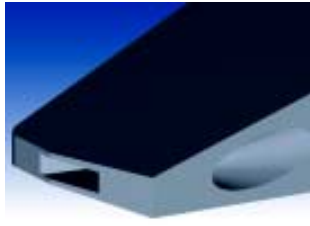
	MATERIAL	HOLE / BOND FLAT	TOOL LENGTH (TL)
C	Cermet composite for Gold Wire (recommended for Low Temperature bonding)	Will rely on specific application requirements (wire diameter used, bond pad size) – see dimension Table * For Oval Hole options please specify HH (Hole Height) & HW (Hole Width)	S = .437 / 11.1 mm
TI	Titanium Carbide Composite for Gold Wire		¾ = .750 / 19.05 mm
W	Tungsten Carbide Ultra Fine Grain for Aluminum Wire		L = .828 / 21.0 mm
			1.00 = 1.00 / 25.4 mm Longer lengths are available consult Bonder manufacturer for specifications.

FOOT OPTIONS	
C	Concave foot design with polished FR and BR with fine matte finish on BF (matte most commonly used with <i>Aluminum wire</i>) for best results specify when the BF is greater than .0015"/38µm.
CM	Concave foot design with FR, BR and BF matte (for <i>Aluminum and Gold wire</i>)
Flat (Optional)	
FM	Flat foot design FR, BR and BF are matte (for <i>Gold Wire</i>) or wire diameter less than .0013"/33µm and BF is less than .0015"/38µm
CGM	Cross Groove with FR and BR matte (for <i>Gold Wire</i>) with a matte Flat BF. Most commonly used on manual and semi automatic bonders where pad size restrictions is not an issue. Not recommended for BF smaller than .0020"/50µm
CCM	Cross Groove with FR and BR matte (for <i>Gold Wire</i>) with a matte Concave BF. Most commonly used on automatic bonders where wire control is critical and pad size is limited. Not recommended for BF smaller than .0020"/50µm

HOW TO ORDER	
SPECIFY	Style/Radius Set – Material – Hole/Bond Flat – Tool Length – Foot Option (For Fine Pitch application below 80µm BPP, refer to page 8 for VR sets to specify, otherwise specify VR and VW) or contact our technical support staff for assistance with your requirements. For Special Shank Style refer to page 61.
EXAMPLE	FP45A - W - 2020 - L - CM 180 - DEG - REV FP38B - TI - 1515 - ¾ - FM VR = Set B FP60B - C - 2025 - L - CGM VR = Set A FP55B-TI-1520-3/4-CGM HH = .0020 HW=.0015 VR Set C

US/UT SERIES - UNIVERSAL BONDING TOOL

The US/UT design incorporates all the latest technical features in semiconductor wire bonding tool designs and is widely used by every bonder manufacturer in the world. The 60° heel with the more squared back or radius area normally will produce a short tail. This tool style is most commonly used where fine pitch bonding is not required.



STANDARD DIMENSIONS									
Tool Styles Radius Set	Wire Feed Angle	Hole / Bond Flat	Hole H in / μm $\pm .0002/5$	Bond Flat BF in / μm $\pm .0002/5$	Foot Width W in / μm $\pm .0002/5$	Tip Thickness T in / μm $\pm .0005/13$	Useable Wire Diameter in / μm		
UT30A US30A	30°	2020	.0020 / 51	.0020 / 51	.0040 / 102	.0150 / 381	.0010 / 25 through .0013 / 33		
		2025	.0020 / 51	.0025 / 64	.0040 / 102	.0150 / 381			
		2520	.0025 / 64	.0020 / 51	.0040 / 102	.0150 / 381			
		2525	.0025 / 64	.0025 / 64	.0040 / 102	.0150 / 381			
	UT38A US38A	38°	3020	.0030 / 76	.0020 / 51	.0050 / 127	.0200 / 508	.0013 / 33 through .0015 / 38	
			3025	.0030 / 76	.0025 / 64	.0050 / 127	.0200 / 508		
			3030	.0030 / 76	.0030 / 76	.0050 / 127	.0200 / 508		
			3035	.0030 / 76	.0035 / 89	.0050 / 127	.0200 / 508		
			3530	.0035 / 89	.0030 / 76	.0060 / 152	.0250 / 635		.0015 / 38 through .0022 / 55
			3535	.0035 / 89	.0035 / 89	.0060 / 152	.0250 / 635		
			3540	.0035 / 89	.0040 / 102	.0060 / 152	.0250 / 635		
			4540	.0045 / 114	.0040 / 102	.0085 / 216	.0190 / 483		.0024 / 61 through .0030 / 76
4545	.0045 / 114	.0045 / 114	.0085 / 216	.0190 / 483					
4550	.0045 / 114	.0050 / 127	.0085 / 216	.0190 / 483					
UT30C US30C	30°	2020	.0020 / 51	.0020 / 51	.0040 / 102	.0140 / 356	.0010 / 25 through .0013 / 33		
		2025	.0020 / 51	.0025 / 64	.0040 / 102	.0140 / 356			
UT38C US38C	38°	2030	.0020 / 51	.0030 / 76	.0040 / 102	.0140 / 356			
UT45A US45A	45°	2020	.0020 / 51	.0020 / 51	.0040 / 102	.0140 / 356	.0010 / 25 through .0013 / 33		
		2025	.0020 / 51	.0025 / 64	.0040 / 102	.0140 / 356			
		2520	.0025 / 64	.0020 / 51	.0040 / 102	.0140 / 356			
		2525	.0025 / 64	.0025 / 64	.0040 / 102	.0140 / 356			
		3020	.0030 / 76	.0020 / 51	.0050 / 127	.0180 / 457	.0013 / 33 through .0015 / 38		
		3025	.0030 / 76	.0025 / 64	.0050 / 127	.0180 / 457			
		3030	.0030 / 76	.0030 / 76	.0050 / 127	.0180 / 457			
		3035	.0030 / 76	.0035 / 89	.0050 / 127	.0180 / 457			
		3530	.0035 / 89	.0030 / 76	.0060 / 152	.0200 / 508	.0015 / 38 through .0022 / 55		
		3535	.0035 / 89	.0035 / 89	.0060 / 152	.0200 / 508			
		3540	.0035 / 89	.0040 / 102	.0060 / 152	.0200 / 508			
		4540	.0045 / 114	.0040 / 102	.0085 / 216	.0250 / 635	.0024 / 61 through .0030 / 76		
4545	.0045 / 114	.0045 / 114	.0085 / 216	.0250 / 635					
4550	.0045 / 114	.0050 / 127	.0085 / 216	.0250 / 635					
UT45C US45C	45°	2020	.0020 / 51	.0020 / 51	.0040 / 102	.0140 / 356	.0010 / 25 through .0013 / 33		
		2025	.0020 / 51	.0025 / 64	.0040 / 102	.0140 / 356			
		2030	.0020 / 51	.0030 / 76	.0040 / 102	.0140 / 356			

US/UT SERIES - GENERAL GUIDELINES ON HOW TO ORDER

STYLE		FEED ANGLE
US	0° Back Angle	30°, 38°, 45°
UT	10° Back Angle	

RADIUS SET	Wire Material	Wire Diameter	Hole Size	FR ± .0001/3	BR ± .0001/3
A	Aluminum	.0010 / 25 - .0013 / 33	.0020/51 - .0025/64	.0010 / 25	.0010 / 25
A	Aluminum	.0013 / 33 - .0015 / 38	.0030 / 76	.0015 / 38	.0015 / 38
A	Aluminum	.0015 / 38 - .0022 / 56	.0035 / 89	.0020 / 51	.0020 / 51
A	Aluminum	.0024 / 61 - .0030 / 76	.0045 / 114	.0025 / 64	.0025 / 64
C	Aluminum/Gold	.0008 / 20 - .0013 / 33	.0020 / 51	.0010 / 25	.0006 / 15

	MATERIAL	HOLE / BOND FLAT	TOOL LENGTH (TL)
C	Cermet composite for Gold Wire (recommended for Low Temperature bonding)	Will rely on specific application requirements (wire diameter used, bond pad size) – see dimension Table * For Oval Hole options please specify HH (Hole Height) & HW (Hole Width)	S = .437 / 11.1 mm
TI	Titanium Carbide Composite for Gold Wire		¾ = .750 / 19.05 mm
W	Tungsten Carbide Ultra Fine Grain for Aluminum Wire		L = .828 / 21.0 mm
			1.00 = 1.00 / 25.4 mm Longer lengths are available consult Bonder manufacturer for specifications.

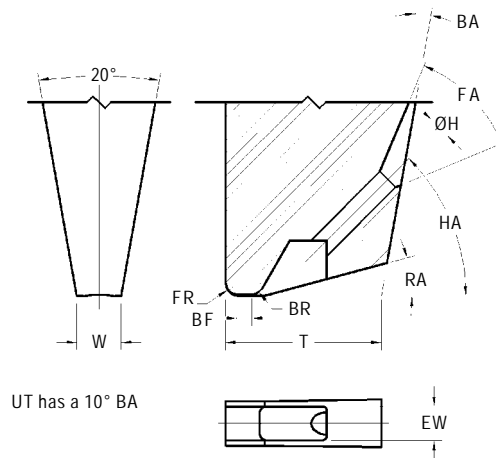
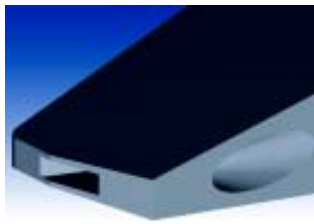
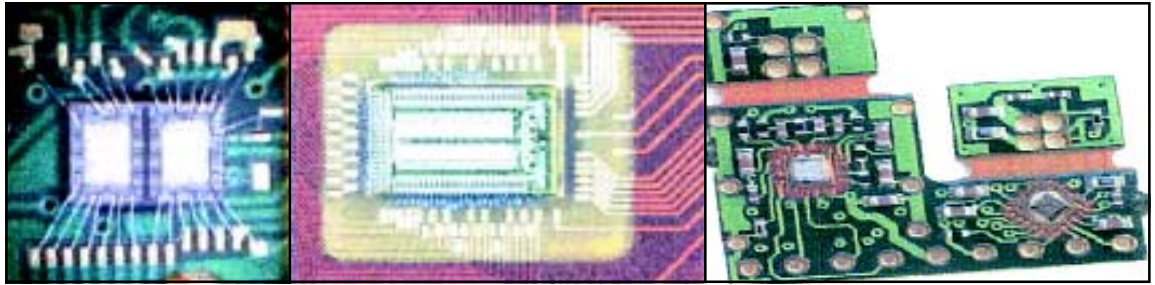
FOOT OPTIONS	
C	Concave foot design with polished FR and BR with fine matte finish on BF (matte most commonly used with <i>Aluminum wire</i>) for best results specify when the BF is greater than .0015"/38µm.
CM	Concave foot design with FR, BR and BF matte (for <i>Aluminum and Gold wire</i>)
CGM	Cross Groove with FR and BR matte (for <i>Gold Wire</i>) with a Flat BF. Most commonly used on manual and semi automatic bonders where pad size restrictions is not an issue.
CCM	Cross Groove with FR and BR matte (for <i>Gold Wire</i>) with a Concave used on automatic bonders where wire control is critical and pad size is limited
Flat (Optional)	
F	The FR and BR are polished. A fine matte finish within the area of the BF.
FM	The FR, BR and BF are matte. Special foot options are available. Consult the factory for recommended dimensions for special foot options.

HOW TO ORDER	
SPECIFY	Style/Radius Set – Material – Hole/Bond Flat – Tool Length – Foot Option (For modifications to standard tools, use part number and specify modified dimensions) or contact our technical support staff for assistance with your requirements. For Special Shank Style refer to page 61.
EXAMPLE	UT30A - W - 2520 - S - CM US38C - TI - 2020 - ¾ - CGM UT45A - W - 3030 - L - C US45A - C - 2025 - L - CGM 180 - DEG - REV (For DIAS Wire Bonder or K&S 8060)

COB SERIES - CHIP-ON-BOARD AUTOBONDING TOOL

Chip-On-Board technology is successfully used to connect semiconductors to PCBs for high integration of electronic systems or microsystems. General conditions and procedures of chip and wire bonding are highly developed for standard applications, but new materials, increasing pin numbers, complex system integration processes and demands for higher reliability in low cost throw-away assemblies and more expensive profile-critical products has led to required improvements in the material, design and life of the tool.

SPT has developed tools in partnership with key OEM's to meet these demands



STANDARD DIMENSIONS								
Tool Styles	Wire Feed Angle	Hole / Bond Flat	Hole H in / μm $\pm .0002/5$	Bond Flat BF in / μm $\pm .0002/5$	Foot Width W in / μm $\pm .0002/5$	Exit Width EW in / μm $\pm .0002/5$	Tip Thickness T in / μm $\pm .0002/5$	Useable Wire Diameter in / μm
UT30A	30°	2020	.0020 / 51	.0020 / 51	.0040 / 102	.0020 / 51	.0150 / 381	.0010 / 25 through .0013 / 33
		2025	.0020 / 51	.0025 / 64	.0040 / 102	.0020 / 51	.0150 / 381	
		2520	.0025 / 64	.0020 / 51	.0040 / 102	.0020 / 51	.0150 / 381	
		2525	.0025 / 64	.0025 / 64	.0040 / 102	.0020 / 51	.0150 / 381	.0013 / 33 through .0015 / 38
		3020	.0030 / 76	.0020 / 51	.0050 / 127	.0030 / 76	.0200 / 508	
		3025	.0030 / 76	.0025 / 64	.0050 / 127	.0030 / 76	.0200 / 508	
		3030	.0030 / 76	.0030 / 76	.0050 / 127	.0030 / 76	.0200 / 508	
		3035	.0030 / 76	.0035 / 89	.0050 / 127	.0030 / 76	.0200 / 508	

COB SERIES - GENERAL GUIDELINES ON HOW TO ORDER

STYLE		FEED ANGLE
UT	UNIVERSAL BONDING TOOL	30°

RADIUS SET	Wire Material	Wire Diameter	Hole Size	FR ± .0001/3	BR ± .0001/3
A	Aluminum	.0010 / 25 - .0013 / 33	.0020/51 - .0025/64	.0010 / 25	.0010 / 25
A	Aluminum	.0013 / 33 - .0015 / 38	.0030 / 76	.0015 / 38	.0015 / 38

MATERIAL	HOLE / BOND FLAT	TOOL LENGTH (TL)
W Tungsten Carbide Ultra Fine Grain for Aluminum Wire	Will rely on specific application requirements (wire diameter used, bond pad size) – see dimension Table	S = .437 / 11.1 mm ¾ = .750 / 19.05 mm L = .828 / 21.0 mm 1.00 = 1.00 / 25.4 mm Longer lengths are available consult Bonder manufacturer for specifications.

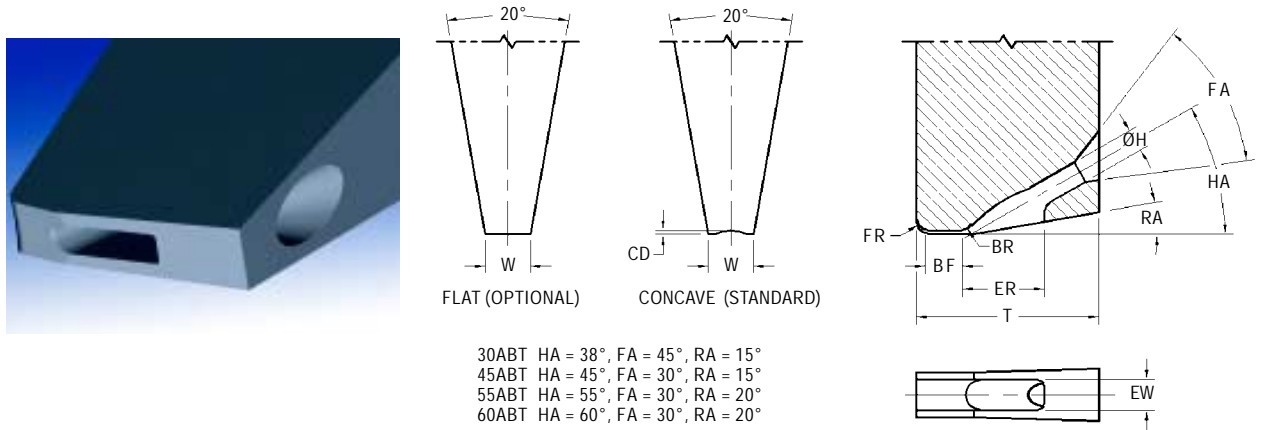
FOOT OPTIONS	
CM	Concave foot design with FR, BR and BF matte (for Aluminum and Gold wire)

HOW TO ORDER	
SPECIFY	Style/Radius Set – Material – Hole/Bond Flat – Tool Length – Foot Option (For modifications to standard tools, use part number and specify modified dimensions) or contact our technical support staff for assistance with your requirements. For Special Shank Style refer to page 61.
EXAMPLE	UT30A - 2520 - L UT30A - 2020 - ¾

ABT SERIES - AUTOBONDING TOOL

The ABT design is the most widely used and recommended tool design for automatic, manual with automatic retrofit and manual ultrasonic wedge bonders due to its highly Accurate bond placement capability.

The back radius area is rounded which keeps the wire in the center of the tool. The lower back heel area of 38° produces a strong first bond transition.



STANDARD DIMENSIONS									
Tool Styles	Wire Feed Angle	Hole / Bond Flat	Hole H in / μm $\pm .0002/5$	Bond Flat BF in / μm $\pm .0002/5$	Front Radius FR in / μm $\pm .0001/3$	Back Radius BR in / μm $\pm .0001/3$	Foot Width W in / μm $\pm .0002/5$	Tip Thickness T in / μm $\pm .0005/13$	Useable Wire Diameter in / μm
30ABT	38°	2015	.0020 / 51	.0015 / 38	.0010 / 25	.0010 / 25	.0040 / 102	.0140 / 356	.0007 / 18 through .0013 / 33
		2020	.0020 / 51	.0020 / 51	.0010 / 25	.0010 / 25	.0040 / 102	.0140 / 356	
		2025	.0020 / 51	.0025 / 64	.0010 / 25	.0010 / 25	.0040 / 102	.0140 / 356	
		2030	.0020 / 51	.0030 / 76	.0010 / 25	.0010 / 25	.0040 / 102	.0140 / 356	
45ABT	45°	2520	.0025 / 64	.0020 / 51	.0010 / 25	.0010 / 25	.0040 / 102	.0140 / 356	.0010 / 25 through .0015 / 38
		2525	.0025 / 64	.0025 / 64	.0010 / 25	.0010 / 25	.0040 / 102	.0140 / 356	
		2530	.0025 / 64	.0030 / 76	.0010 / 25	.0010 / 25	.0040 / 102	.0140 / 356	
		2535	.0025 / 64	.0035 / 89	.0010 / 25	.0010 / 25	.0040 / 102	.0150 / 381	
		2540	.0025 / 64	.0040 / 102	.0010 / 25	.0010 / 25	.0040 / 102	.0150 / 381	
30ABT	38°	3020	.0030 / 76	.0020 / 51	.0010 / 25	.0010 / 25	.0050 / 127	.020 / 508	.0015 / 38 through .0020 / 51
		3025	.0030 / 76	.0025 / 64	.0010 / 25	.0010 / 25	.0050 / 127	.020 / 508	
		3030	.0030 / 76	.0030 / 76	.0010 / 25	.0010 / 25	.0050 / 127	.020 / 508	
		3035	.0030 / 76	.0035 / 89	.0010 / 25	.0010 / 25	.0050 / 127	.020 / 508	
		3040	.0030 / 76	.0040 / 102	.0010 / 25	.0010 / 25	.0050 / 127	.020 / 508	
45ABT 55ABT 60ABT	45° 55° 60°	3020	.0030 / 76	.0020 / 51	.0010 / 25	.0010 / 25	.0050 / 127	.0180 / 457	
		3025	.0030 / 76	.0025 / 64	.0010 / 25	.0010 / 25	.0050 / 127	.0180 / 457	
		3030	.0030 / 76	.0030 / 76	.0010 / 25	.0010 / 25	.0050 / 127	.0180 / 457	
		3035	.0030 / 76	.0035 / 89	.0010 / 25	.0010 / 25	.0050 / 127	.0180 / 457	
		3040	.0030 / 76	.0040 / 102	.0010 / 25	.0010 / 25	.0050 / 127	.0180 / 457	

ABT SERIES - GENERAL GUIDELINES ON HOW TO ORDER

STYLE		FEED ANGLE
ABT	AUTO BONDING TOOL	38°, 45°, 55°, 60°

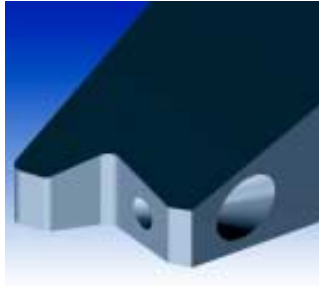
	MATERIAL	HOLE / BOND FLAT	TOOL LENGTH (TL)
C	Cermet composite for Gold Wire (recommended for Low Temperature bonding)	Will rely on specific application requirements (wire diameter used, bond pad size) – see dimension Table * For Oval Hole options please specify HH (Hole Height) & HW (Hole Width)	S = .437 / 11.1 mm
TI	Titanium Carbide Composite for Gold Wire		¾ = .750 / 19.05 mm
W	Tungsten Carbide Ultra Fine Grain for Aluminum Wire		L = .828 / 21.0 mm 1.00 = 1.00 / 25.4 mm Longer lengths are available consult Bonder manufacturer for specifications.

FOOT OPTIONS	
C	Concave foot design with polished FR and BR with matte finish on BF (matte most commonly used with <i>Aluminum wire</i>) for best results specify when the BF is greater than .0015"/38µm.
CM	Concave foot design with FR, BR and BF matte (for <i>Aluminum and Gold wire</i>)
Flat (Optional)	
F	The FR and BR are polished. A fine matte finish is within the area of the BF.
FM	The FR, BR and BF are matte.
CGM	Cross Groove with FR and BR matte (for <i>Gold Wire</i>) with a matte Flat BF. Most commonly used on manual and semi automatic bonders where pad size restrictions is not an issue. Not recommended for BF smaller than .0020"/50µm
CCM	Cross Groove with FR and BR matte (for <i>Gold Wire</i>) with a Concave used on automatic bonders where wire control is critical and pad size is limited. Not recommended for BF smaller than .0020"/50µm

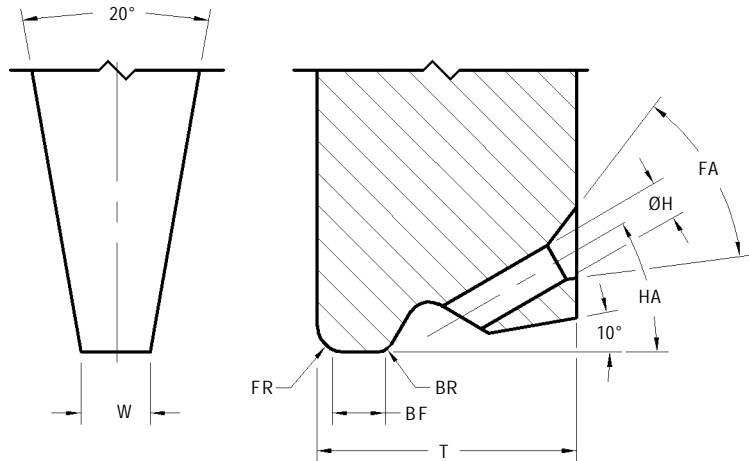
HOW TO ORDER	
SPECIFY	Style – Material – Hole/Bond Flat – Tool Length – Foot Option (For modifications to standard tools, use part number and specify modified dimensions) or contact our technical support staff for assistance with your requirements. For Special Shank Style refer to page 61.
EXAMPLE	30ABT - W - 2520 - L - CM 180 - DEG - REV (For DIAS Wire Bonder or K&S 8060) 45ABT - TI - 2020 - ¾ - CGM

M SERIES - MICROWAVE BONDING TOOLS

Microwave devices commonly have bonding pads as small as .001"/25µm square. They are typically bonded with .0005"/13µm to .001"/25µm diameter gold wires. Microwave devices have some special requirements that are not seen in monolithic devices special requirements include the variety of chips within the package, step heights within the products that require deep access requirements, as well as critical loop shapes for tuning of the device. We have developed a range of tools to meet the small foot print, and critical loop requirements.



M30	HA = 30°, FA = 45°
M38	HA = 38°, FA = 45°
M45	HA = 45°, FA = 45°
M55	HA = 55°, FA = 30°
M60	HA = 60°, FA = 30°



STANDARD DIMENSIONS

Tool Styles	Hole Bond Flat	Hole H in / µm ±.0002/5	Bond Flat BF in / µm ±.0001/3	Front Radius FR in / µm ±.0001/3	Back Radius BR in / µm ±.0001/3	Foot Width W in / µm ±.0002/5	Tip Thickness T 30° in / µm ±.0005/13	Tip Thickness T 45° in / µm ±.0005/13	Tip Thickness T 55°/60° in / µm ±.0005/13	Useable Wire Diameter in / µm
M30A	1005	.0010 / 25	.0005 / 13	.0010 / 25	.0006 / 15	.0030 / 76	.0100 / 254	.0080 / 203	.0080 / 203	.0005 / 13 through .0010 / 25
	1007	.0010 / 25	.0007 / 18	.0010 / 25	.0006 / 15	.0030 / 76	.0100 / 254	.0080 / 203	.0080 / 203	
	1010	.0010 / 25	.0010 / 25	.0010 / 25	.0006 / 15	.0030 / 76	.0100 / 254	.0080 / 203	.0080 / 203	
	1505	.0015 / 38	.0005 / 13	.0010 / 25	.0006 / 15	.0030 / 76	.0100 / 254	.0080 / 203	.0080 / 203	
M38A	1507	.0015 / 38	.0007 / 18	.0010 / 25	.0006 / 15	.0030 / 76	.0100 / 254	.0080 / 203	.0080 / 203	
	1510	.0015 / 38	.0010 / 25	.0010 / 25	.0006 / 15	.0030 / 76	.0100 / 254	.0080 / 203	.0080 / 203	
	1513	.0015 / 38	.0013 / 33	.0010 / 25	.0006 / 15	.0030 / 76	.0100 / 254	.0080 / 203	.0080 / 203	
M45A	1515	.0015 / 38	.0015 / 38	.0010 / 25	.0006 / 15	.0030 / 76	.0100 / 254	.0080 / 203	.0080 / 203	
	1520	.0015 / 38	.0020 / 51	.0010 / 25	.0006 / 15	.0030 / 76	.0100 / 254	.0080 / 203	.0080 / 203	
	M55A	2005	.0200 / 51	.0005 / 13	.0010 / 25	.0006 / 15	.0040 / 102	.0100 / 254	.0080 / 203	
2007		.0200 / 51	.0007 / 18	.0010 / 25	.0006 / 15	.0040 / 102	.0100 / 254	.0080 / 203	.0080 / 203	
2010		.0200 / 51	.0010 / 25	.0010 / 25	.0006 / 15	.0040 / 102	.0100 / 254	.0080 / 203	.0080 / 203	
M60A	2013	.0200 / 51	.0013 / 33	.0010 / 25	.0006 / 15	.0040 / 102	.0120 / 305	.0100 / 254	.0090 / 229	
	2015	.0200 / 51	.0015 / 38	.0010 / 25	.0006 / 15	.0040 / 102	.0120 / 305	.0100 / 254	.0090 / 229	
	2020	.0200 / 51	.0020 / 51	.0010 / 25	.0006 / 15	.0040 / 102	.0120 / 305	.0100 / 254	.0090 / 229	
	M30B	1005	.0010 / 25	.0005 / 13	.0004 / 10	.0004 / 10	.0030 / 76	.0080 / 203	.0080 / 203	
1007		.0010 / 25	.0007 / 18	.0004 / 10	.0004 / 10	.0030 / 76	.0080 / 203	.0080 / 203	.0080 / 203	
1010		.0010 / 25	.0010 / 25	.0004 / 10	.0004 / 10	.0030 / 76	.0080 / 203	.0080 / 203	.0080 / 203	
1505		.0015 / 38	.0005 / 13	.0004 / 10	.0004 / 10	.0030 / 76	.0080 / 203	.0080 / 203	.0080 / 203	
M38B	1507	.0015 / 38	.0007 / 18	.0004 / 10	.0004 / 10	.0030 / 76	.0080 / 203	.0080 / 203	.0080 / 203	
	1510	.0015 / 38	.0010 / 25	.0004 / 10	.0004 / 10	.0030 / 76	.0080 / 203	.0080 / 203	.0080 / 203	
	1513	.0015 / 38	.0013 / 33	.0004 / 10	.0004 / 10	.0030 / 76	.0100 / 254	.0080 / 203	.0080 / 203	
M45B	1515	.0015 / 38	.0015 / 38	.0004 / 10	.0004 / 10	.0030 / 76	.0100 / 254	.0080 / 203	.0080 / 203	
	1520	.0015 / 38	.0020 / 51	.0004 / 10	.0004 / 10	.0030 / 76	.0100 / 254	.0080 / 203	.0080 / 203	
	M55B	2005	.0020 / 51	.0005 / 13	.0004 / 10	.0004 / 10	.0040 / 102	.0100 / 254	.0080 / 203	.0080 / 203
2007		.0020 / 51	.0007 / 18	.0004 / 10	.0004 / 10	.0040 / 102	.0100 / 254	.0080 / 203	.0080 / 203	
2010		.0020 / 51	.0010 / 25	.0004 / 10	.0004 / 10	.0040 / 102	.0100 / 254	.0080 / 203	.0080 / 203	
M60B	2013	.0020 / 51	.0013 / 33	.0004 / 10	.0004 / 10	.0040 / 102	.0120 / 305	.0080 / 203	.0080 / 203	
	2015	.0020 / 51	.0015 / 38	.0004 / 10	.0004 / 10	.0040 / 102	.0120 / 305	.0080 / 203	.0080 / 203	
	2020	.0020 / 51	.0020 / 51	.0004 / 10	.0004 / 10	.0040 / 102	.0120 / 305	.0080 / 203	.0080 / 203	

"W dimension .002 to .0025 only for hole size .001 to .0015 "

Refer to page 17 for "How To Order"

MICROWAVE BONDING TOOLS - GENERAL GUIDELINES ON HOW TO ORDER

STYLE		FEED ANGLE
M = MICROWAVE	SLIMLINE BACK	30°, 38°, 45°, 55°, 60°

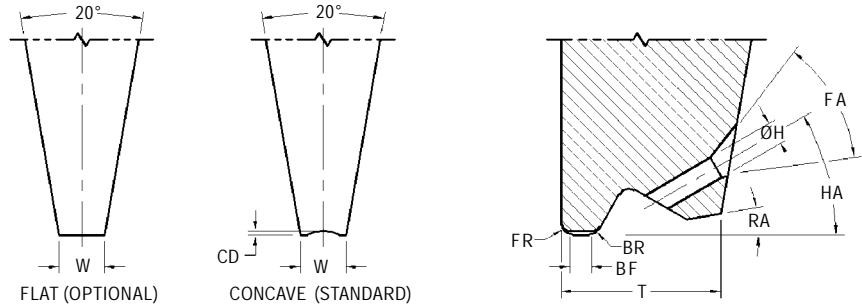
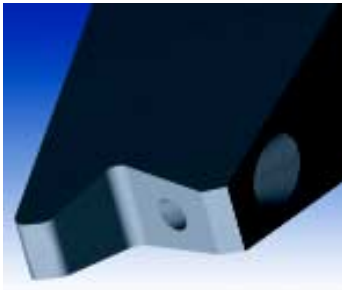
MATERIAL	HOLE / BOND FLAT	TOOL LENGTH (TL)
C Cermet composite for Gold Wire (recommended for Low Temperature bonding)	Will rely on specific application requirements (wire diameter used, bond pad size) – see dimension Table * For Oval Hole options please specify HH (Hole Height) & HW (Hole Width)	S = .437 / 11.1 mm
TI Titanium Carbide Composite for Gold Wire		¾ = .750 / 19.05 mm
W Tungsten Carbide Ultra Fine Grain for Aluminum Wire		L = .828 / 21.0 mm 1.00 = 1.00 / 25.4 mm Longer lengths are available consult Bonder manufacturer for specifications.

FOOT OPTIONS	
FM	Flat foot design FR, BR and BF are matte (for Gold Wire)
CGM	The FR and BR and BF are matte. Not recommended for BF smaller than .0020"/50µm

HOW TO ORDER	
SPECIFY	Style – Material – Hole/Bond Flat – Tool Length – Foot Option (For modifications to standard tools, use part number and specify modified dimensions) or contact our technical support staff for assistance with your requirements. For Special Shank Style refer to page 61.
EXAMPLE	M30A –TI –1507 –L - FM M45B –TI –2020 –L - FM M55A –TI –1513 –L – FM

STANDARD BONDING TOOL SERIES

The standard 10° back bonding wedge is designed for use with aluminum wire in all conventional manual bonding machines. The notched tip minimizes wire drag during the looping formation preventing heel cracks and broken wires.



- 1001 HA = 30°, FA = 45°, RA = 15°
- 1002 HA = 45°, FA = 45°, RA = 15°
- 1110 HA = 60°, FA = 30°, RA = 20°

STANDARD DIMENSIONS

Tool Styles	Hole / Bond Flat	Hole H	Bond Flat BF	Front Radius FR	Back Radius BR	Foot Width W	Foot Width W	Tip Thickness T	Tip Thickness T	Tip Thickness T	Useable Wire Diameter in / μm
		in / μm ±.0002/5	in / μm ±.0002/5	in / μm ±.0001/3	in / μm ±.0001/3	1001, 1002 in / μm ±.0002/5	1110 in / μm ±.0002/5	1001 in / μm ±.0005/13	1002 in / μm ±.0005/13	1110 in / μm ±.0005/13	
1001A	2020	.0020 / 51	.0020 / 51	.0010 / 25	.0010 / 25	.0040 / 102	.0065 / 165	.0150 / 381	.0140 / 356	.0120 / 305	.0007 / 18 through .0013 / 33
	2025	.0020 / 51	.0025 / 64	.0010 / 25	.0010 / 25	.0040 / 102	.0065 / 165	.0150 / 381	.0140 / 356	.0120 / 305	
	2030	.0020 / 51	.0030 / 76	.0010 / 25	.0010 / 25	.0040 / 102	.0065 / 165	.0150 / 381	.0140 / 356	.0140 / 356	
	2515	.0025 / 64	.0015 / 38	.0010 / 25	.0010 / 25	.0040 / 102	.0065 / 165	.0150 / 381	.0140 / 356	.0120 / 305	
	2520	.0025 / 64	.0020 / 51	.0010 / 25	.0010 / 25	.0040 / 102	.0065 / 165	.0150 / 381	.0140 / 356	.0120 / 305	
1002A	2525	.0025 / 64	.0025 / 64	.0010 / 25	.0010 / 25	.0040 / 102	.0065 / 165	.0150 / 381	.0140 / 356	.0120 / 305	.0010 / 25 through .0015 / 38
	2530	.0025 / 64	.0030 / 76	.0010 / 25	.0010 / 25	.0040 / 102	.0065 / 165	.0150 / 381	.0140 / 356	.0140 / 356	
1110A	2535	.0025 / 64	.0035 / 89	.0015 / 38	.0010 / 25	.0050 / 127	.0065 / 165	.0180 / 457	.0150 / 381	.0140 / 356	.0015 / 38 through .0017 / 40
	2540	.0025 / 64	.0040 / 102	.0015 / 38	.0010 / 25	.0050 / 127	.0065 / 165	.0180 / 457	.0150 / 381	.0140 / 356	
	3020	.0030 / 76	.0020 / 51	.0015 / 38	.0015 / 38	.0050 / 127	.0065 / 165	.0200 / 508	.0180 / 457	.0180 / 457	
	3025	.0030 / 76	.0025 / 64	.0015 / 38	.0015 / 38	.0050 / 127	.0065 / 165	.0200 / 508	.0180 / 457	.0180 / 457	
	3030	.0030 / 76	.0030 / 76	.0015 / 38	.0015 / 38	.0050 / 127	.0065 / 165	.0200 / 508	.0180 / 457	.0180 / 457	
1001B	3035	.0030 / 76	.0035 / 89	.0015 / 38	.0015 / 38	.0050 / 127	.0065 / 165	.0200 / 508	.0180 / 457	.0180 / 457	.0007 / 18 through .0013 / 33
	3040	.0030 / 76	.0040 / 102	.0015 / 38	.0015 / 38	.0050 / 127	.0065 / 165	.0200 / 508	.0180 / 457	.0180 / 457	
	2020	.0020 / 51	.0020 / 51	.0015 / 38	.0010 / 25	.0040 / 102	.0065 / 165	.0150 / 381	.0140 / 356	.0120 / 305	
	2025	.0020 / 51	.0025 / 64	.0015 / 38	.0010 / 25	.0040 / 102	.0065 / 165	.0150 / 381	.0140 / 356	.0140 / 356	
	2030	.0020 / 51	.0030 / 76	.0015 / 38	.0010 / 25	.0040 / 102	.0065 / 165	.0150 / 381	.0140 / 356	.0140 / 356	
1002B	2515	.0025 / 64	.0015 / 38	.0015 / 38	.0010 / 25	.0040 / 102	.0065 / 165	.0150 / 381	.0140 / 356	.0120 / 305	.0010 / 25 through .0015 / 38
	2520	.0025 / 64	.0020 / 51	.0015 / 38	.0010 / 25	.0040 / 102	.0065 / 165	.0150 / 381	.0140 / 356	.0120 / 305	
1110B	2525	.0025 / 64	.0025 / 64	.0015 / 38	.0010 / 25	.0050 / 127	.0065 / 165	.0150 / 381	.0140 / 356	.0140 / 356	.0015 / 38
	2530	.0025 / 64	.0030 / 76	.0015 / 38	.0010 / 25	.0050 / 127	.0065 / 165	.0200 / 508	.0140 / 356	.0140 / 356	

STANDARD BONDING TOOLS - GENERAL GUIDELINES ON HOW TO ORDER

STYLE		FEED ANGLE
1001	STANDARD 10° BACK	30°
1002		45°
1110		60°

MATERIAL	HOLE / BOND FLAT	TOOL LENGTH (TL)
C	Will rely on specific application requirements (wire diameter used, bond pad size) – see dimension Table * For Oval Hole options please specify HH (Hole Height) & HW (Hole Width)	S = .437 / 11.1 mm
TI		3/4 = .750 / 19.05 mm
W		L = .828 / 21.0 mm 1.00 = 1.00 / 25.4 mm
		Longer lengths are available consult Bonder manufacturer for specifications.

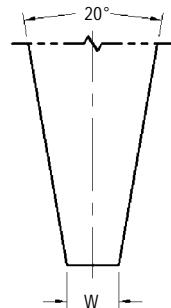
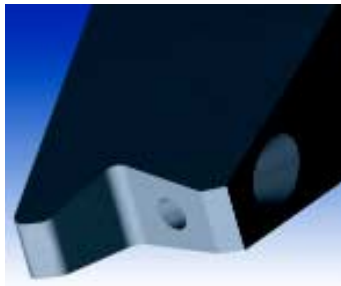
FOOT OPTIONS	
Concave (Standard) The Concave Depth (CD) is typically 10 to 15% of the usable wire diameter. There are small side flats on the edges to reduce edge chipping and minimize tool marks on the bond pad if the wire is missing.	
C	The FR and BR are polished. A fine matte finish within the area of the BF (Most Commonly Specified)
CM	The FR, BR and BF are matte.
CGM	Cross Groove foot design with FR, BR, and BF matte (for <i>Gold Wire</i>). Not recommended for BF smaller than .0020"/50µm
Flat (Optional)	
F	The FR and BR are polished. A fine matte finish within the area of the BF.
FM	The FR, BR and BF are matte. Special foot options are available. Consult the factory for recommended dimensions for special foot options.

HOW TO ORDER	
SPECIFY	Style – Material – Hole/Bond Flat – Tool Length – Foot Option (For modifications to standard tools, use part number and specify modified dimensions) or contact our technical support staff for assistance with your requirements. For Special Shank Style refer to page 61.
EXAMPLE	1001A-W-2525-L-C 1001B-W-2530-S-C

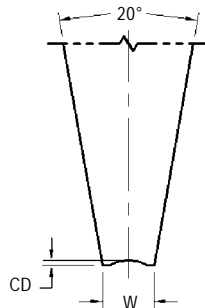
SLIMLINE NOTCH SERIES - BONDING TOOLS

The 0° back bonding wedge is designed for use with aluminum wire in all conventional bonding machines. The 0° back angle is designed to solve problems of package wall height clearance around the lead.

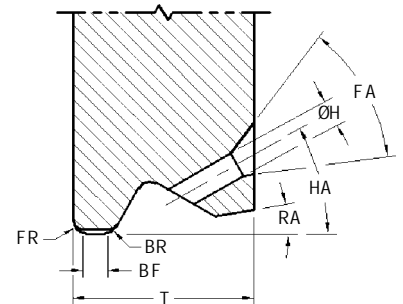
The notched tip minimizes wire drag during the looping formation preventing heel cracks and broken wires.



FLAT (OPTIONAL)



CONCAVE (STANDARD)



1200	HA = 30°, FA = 45°, RA = 15°
1300	HA = 45°, FA = 45°, RA = 15°
1400	HA = 55°, FA = 30°, RA = 20°
1100	HA = 60°, FA = 30°, RA = 20°

STANDARD DIMENSIONS

Tool Styles	Hole / Bond Flat	Hole H	Bond Flat BF	Front Radius FR	Back Radius BR	Foot Width W	Foot Width W	Tip Thickness T	Tip Thickness T	Tip Thickness T	Useable Wire Diameter in / μ m	
		in / μ m $\pm .0002/5$	in / μ m $\pm .0002/5$	in / μ m $\pm .0001/3$	in / μ m $\pm .0001/3$	1200, 1300 in / μ m $\pm .0002/5$	1400 / 1100 in / μ m $\pm .0002/5$	1200 in / μ m $\pm .0005/13$	1300 in / μ m $\pm .0005/13$	1400 / 1100 in / μ m $\pm .0005/13$		
1200A	2025	.0020 / 51	.0025 / 64	.0010 / 25	.0010 / 25	.0040 / 102	.0065 / 165	.0150 / 381	.0140 / 356	.0120 / 305	.0007 / 18 through .0013 / 33	
	2030	.0020 / 51	.0030 / 76	.0010 / 25	.0010 / 25	.0040 / 102	.0065 / 165	.0150 / 381	.0140 / 356	.0140 / 356		
	2520	.0025 / 64	.0020 / 51	.0010 / 25	.0010 / 25	.0040 / 102	.0065 / 165	.0150 / 381	.0140 / 356	.0120 / 305	.0010 / 25 through .0013 / 33	
	2525	.0025 / 64	.0025 / 64	.0010 / 25	.0010 / 25	.0040 / 102	.0065 / 165	.0150 / 381	.0140 / 356	.0120 / 305		
	2530	.0025 / 64	.0030 / 76	.0010 / 25	.0010 / 25	.0040 / 102	.0065 / 165	.0150 / 381	.0140 / 356	.0140 / 356		
1300A	2535	.0025 / 64	.0035 / 89	.0015 / 38	.0010 / 25	.0050 / 127	.0065 / 165	.0180 / 457	.0150 / 381	.0140 / 356	.0013 / 33	
1400A	2540	.0025 / 64	.0040 / 102	.0015 / 38	.0010 / 25	.0050 / 127	.0065 / 165	.0180 / 457	.0150 / 381	.0140 / 356		
1400A	3020	.0030 / 76	.0020 / 51	.0015 / 38	.0015 / 38	.0050 / 127	.0065 / 165	.0200 / 508	.0180 / 457	.0180 / 457	.0015 / 38 through .0017 / 40	
	3025	.0030 / 76	.0025 / 64	.0015 / 38	.0015 / 38	.0050 / 127	.0065 / 165	.0200 / 508	.0180 / 457	.0180 / 457		
1100A	3030	.0030 / 76	.0030 / 76	.0015 / 38	.0015 / 38	.0050 / 127	.0065 / 165	.0200 / 508	.0180 / 457	.0180 / 457	.0017 / 40	
	3035	.0030 / 76	.0035 / 89	.0015 / 38	.0015 / 38	.0050 / 127	.0065 / 165	.0200 / 508	.0180 / 457	.0180 / 457		
	3040	.0030 / 76	.0040 / 102	.0015 / 38	.0015 / 38	.0050 / 127	.0065 / 165	.0200 / 508	.0180 / 457	.0180 / 457		
	3530	.0035 / 89	.0030 / 76	.0020 / 51	.0020 / 51	.0060 / 152	.0065 / 165	.0250 / 635	.0220 / 559	.0210 / 533	.0017 / 40 through .0022 / 55	
	3535	.0035 / 89	.0035 / 89	.0020 / 51	.0020 / 51	.0060 / 152	.0065 / 165	.0250 / 635	.0220 / 559	.0210 / 533		
3540	.0035 / 89	.0040 / 102	.0020 / 51	.0020 / 51	.0060 / 152	.0065 / 165	.0250 / 635	.0220 / 559	.0210 / 533			
1200B	3545	.0035 / 89	.0045 / 114	.0020 / 51	.0020 / 51	.0060 / 152	.0065 / 165	.0250 / 635	.0220 / 559	.0210 / 533	.0017 / 40 through .0022 / 55	
	3550	.0035 / 89	.0050 / 127	.0020 / 51	.0020 / 51	.0060 / 152	.0065 / 165	.0250 / 635	.0220 / 559	.0210 / 533		
	1200B	2025	.0020 / 51	.0025 / 64	.0015 / 38	.0010 / 25	.0040 / 102	.0065 / 165	.0150 / 381	.0140 / 356	.0140 / 356	.0007 / 18 through .0013 / 33
	1300B	2030	.0020 / 51	.0030 / 76	.0015 / 38	.0010 / 25	.0040 / 102	.0065 / 165	.0150 / 381	.0140 / 356	.0140 / 356	
	1400B	2520	.0025 / 64	.0020 / 51	.0015 / 38	.0010 / 25	.0040 / 102	.0065 / 165	.0150 / 381	.0140 / 356	.0120 / 305	.0010 / 25 through .0013 / 33
1100B	2525	.0025 / 64	.0025 / 64	.0015 / 38	.0010 / 25	.0050 / 127	.0065 / 165	.0150 / 381	.0140 / 356	.0140 / 356		
	2530	.0025 / 64	.0030 / 76	.0015 / 38	.0010 / 25	.0050 / 127	.0065 / 165	.0200 / 508	.0140 / 356	.0140 / 356		

- For wire diameters .0010"/25 μ m or less consider the Microwave Bonding Tools
- Microwave Style Tool is recommended for Hole = .0020" and BF = .0020" and below.

SLIMLINE NOTCH SERIES - GENERAL GUIDELINES ON HOW TO ORDER

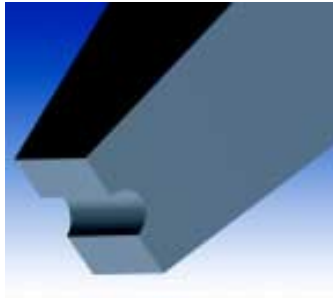
STYLE		FEED ANGLE
1200	SLIMLINE BACK	30°
1300		45°
1400		55°
1100		60°

MATERIAL	HOLE / BOND FLAT	TOOL LENGTH (TL)
C	Will rely on specific application requirements (wire diameter used, bond pad size) – see dimension Table * For Oval Hole options please specify HH (Hole Height) & HW (Hole Width)	S = .437 / 11.1 mm
TI		3/4 = .750 / 19.05 mm
W		L = .828 / 21.0 mm 1.00 = 1.00 / 25.4 mm
		Longer lengths are available consult Bonder manufacturer for specifications.

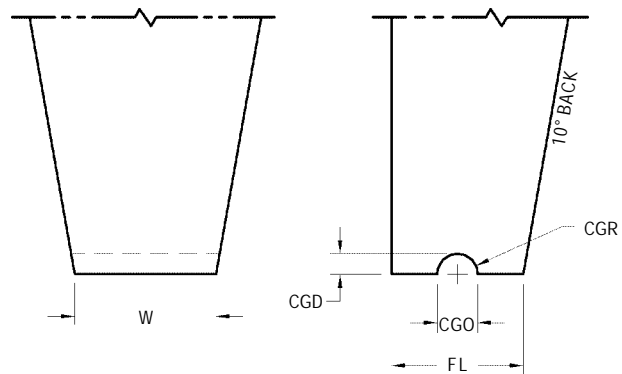
FOOT OPTIONS	
Concave (Standard) The Concave Depth (CD) is typically 10 to 15% of the usable wire diameter. There are small side flats on the edges to reduce edge chipping and minimize tool marks on the bond pad if the wire is missing.	
C	The FR and BR are polished. A fine matte finish within the area of the BF (Most Commonly Specified)
CM	The FR, BR and BF are matte.
Flat (Optional)	
F	The FR and BR are polished. A fine matte finish within the area of the BF (Most Commonly Specified)
FM	The FR, BR and BF are matte. Special foot options are available. Consult the factory for recommended dimensions for special foot options.
CG	The FR and BR are polished. A fine matte finish is within the area of the BF. Not recommended for BF smaller than .0020"/50µm
CGM	The FR and BR and BF are matte. Not recommended for BF smaller than .0020"/50µm

HOW TO ORDER	
SPECIFY	Style – Material – Hole/Bond Flat – Tool Length – Foot Option (For modifications to standard tools, use part number and specify modified dimensions) or contact our technical support staff for assistance with your requirements. For Special Shank Style refer to page 61.
EXAMPLE	1200A-W-2525-L-C 1200B-W-2530-S-C 1300A-W-2020-3/4-FM 1110A-W-2025-S-C

SPECIAL BONDING TOOLS



**1008A SIDE WIRE
BONDING WEDGE**



STANDARD DIMENSIONS

Tool Styles	Foot Length FL	Foot Width W	Cross Groove Depth CGD	Cross Groove Radius CGR	Useable Wire Diameter WD
	in / μm $\pm .0002/5$	in / μm $\pm .0002/5$	in / μm $\pm .0001/3$	in / μm $\pm .0001/3$	in / μm (Ref)
1008A	.0030 / 76	.0020 / 51 to .0040 / 102	.0005 / 13	.0005 / 13	.0010 / 25
1008A	.0035 / 89	.0020 / 51 to .0040 / 102	.0005 / 13	.0005 / 13	.0010 / 25
1008A	.0040 / 102	.0020 / 51 to .0040 / 102	.0005 / 13	.0005 / 13	.0010 / 25
1008A	.0045 / 114	.0020 / 51 to .0040 / 102	.0005 / 13	.0005 / 13	.0010 / 25
1008A	.0050 / 127	.0020 / 51 to .0040 / 102	.0005 / 13	.0005 / 13	.0010 / 25
1008A	.0060 / 152	.0020 / 51 to .0040 / 102	.0005 / 13	.0005 / 13	.0010 / 25
1008A	.0045 / 114	.0030 / 76 to .0050 / 127	.0008 / 19	.0008 / 19	.0015 / 38
1008A	.0050 / 127	.0030 / 76 to .0050 / 127	.0008 / 19	.0008 / 19	.0015 / 38
1008A	.0060 / 152	.0030 / 76 to .0050 / 127	.0008 / 19	.0008 / 19	.0015 / 38
1008A	.0070 / 178	.0030 / 76 to .0050 / 127	.0008 / 19	.0008 / 19	.0015 / 38
1008A	.0080 / 203	.0030 / 76 to .0050 / 127	.0008 / 19	.0008 / 19	.0015 / 38
1008A	.0060 / 152	.0040 / 102 to .0060 / 152	.0010 / 25	.0010 / 25	.0020 / 51
1008A	.0070 / 178	.0040 / 102 to .0060 / 152	.0010 / 25	.0010 / 25	.0020 / 51
1008A	.0080 / 203	.0040 / 102 to .0060 / 152	.0010 / 25	.0010 / 25	.0020 / 51
1008A	.0090 / 229	.0040 / 102 to .0060 / 152	.0010 / 25	.0010 / 25	.0020 / 51
1008A	.0100 / 254	.0040 / 102 to .0060 / 152	.0010 / 25	.0010 / 25	.0020 / 51

SPECIAL BONDING TOOLS - GENERAL GUIDELINES ON HOW TO ORDER

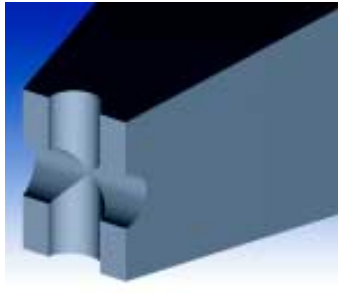
STYLE	
1008A	SIDE WIRE BONDING WEDGE STANDARD 10° BACK

	MATERIAL	FOOT LENGTH	TOOL LENGTH (TL)
TI	Titanium Carbide Composite for Gold Wire	Will rely on specific application requirements (wire diameter used, bond pad size) – see dimension Table	S = .437 / 11.1 mm
W	Tungsten Carbide Ultra Fine Grain for Aluminum Wire		$\frac{3}{4}$ = .750 / 19.05 mm L = .828 / 21.0 mm 1.00 = 1.00 / 25.4 mm Longer lengths are available consult Bonder manufacturer for specifications.

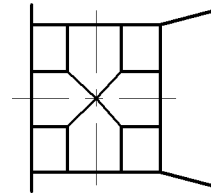
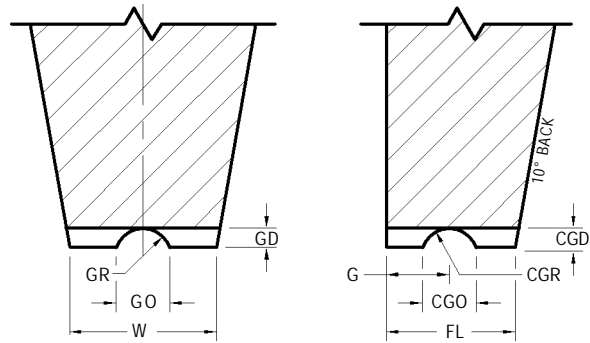
FOOT OPTIONS	
M	Matte finish on tip

HOW TO ORDER	
SPECIFY	Style – Material – Tool Diameter – Tool Length – Foot Design (Specify FL, W, CGD and CGR dimensions). For Special Shank Style refer to page 61.
EXAMPLE	1008A-W-1/16-L-M FL=.003, W = .004, CGD = CGR = .0005

SPECIAL BONDING TOOLS



**XGR INSULATED WIRE
BONDING WEDGE**



STANDARD DIMENSIONS

Tool Styles	Foot Length FL	Foot Width W	Groove Depth Cross Groove Depth	Groove Radius Cross Groove Radius	Groove Opening Cross Groove Opening	Useable Wire Diameter WD
	in / μm $\pm .0002/5$	in / μm $\pm .0002/5$	GD / CGD in / μm $\pm .0001/3$	GR / CGR in / μm (Ref)	GO / CGO in / μm $\pm .0002/5$	
XGR	.0035 / 89	.0040 / 102	.0005 / 13	.0006 / 15	.0012 / 30	.0010 / 25
XGR	.0030 / 76	.0035 / 89	.0005 / 13	.0006 / 15	.0012 / 30	.0010 / 25
XGR	.0035 / 89	.0040 / 102	.0005 / 13	.0008 / 20	.0015 / 38	.0010 / 25
XGR	.0030 / 76	.0035 / 89	.0005 / 13	.0008 / 20	.0015 / 38	.0010 / 25
XGR	.0045 / 114	.0055 / 140	.0008 / 20	.0010 / 25	.0020 / 51	.0015 / 38
XGR	.0055 / 140	.0060 / 152	.0008 / 20	.0010 / 25	.0020 / 51	.0015 / 38
XGR	.0055 / 140	.0060 / 152	.0008 / 20	.0012 / 30	.0023 / 58	.0015 / 38
XGR	.0045 / 114	.0055 / 140	.0008 / 20	.0012 / 30	.0023 / 58	.0015 / 38
XGR	.0060 / 152	.0070 / 178	.0010 / 25	.0012 / 30	.0024 / 61	.0020 / 51
XGR	.0070 / 178	.0080 / 230	.0010 / 25	.0012 / 30	.0024 / 61	.0020 / 51
XGR	.0060 / 152	.0070 / 178	.0010 / 25	.0015 / 38	.0028 / 71	.0020 / 51
XGR	.0070 / 178	.0080 / 203	.0010 / 25	.0015 / 38	.0028 / 71	.0020 / 51

SPECIAL BONDING TOOLS - GENERAL GUIDELINES ON HOW TO ORDER

STYLE	
XGR	INSULATED WIRE BONDING WEDGE STANDARD 10° BACK

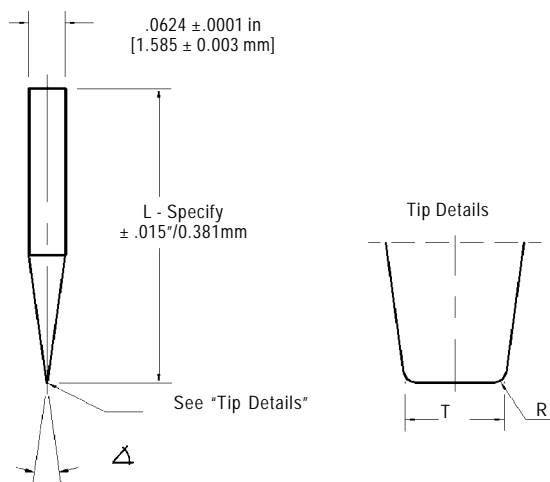
	MATERIAL	FOOT LENGTH	TOOL LENGTH (TL)
TI	Titanium Carbide Composite for Gold Wire	Will rely on specific application requirements (wire diameter used, bond pad size) – see dimension Table	S = .437 / 11.1 mm
W	Tungsten Carbide Ultra Fine Grain for Aluminum Wire		$\frac{3}{4}$ = .750 / 19.05 mm L = .828 / 21.0 mm 1.00 = 1.00 / 25.4 mm Longer lengths are available consult Bonder manufacturer for specifications.

FOOT OPTIONS	
M	Matte finish on tip

HOW TO ORDER	
SPECIFY	Style – Material – Tool Diameter – Tool Length – Foot Design (Specify FL, W, GD, CGD, GR and CGR dimensions) For Special Shank Style refer to page 61.
EXAMPLE	XGR – W – 1/16 – L - M FL=.0055, W = .0060, GD = CGD = .0008, GR = CGR = .0010

PF NEEDLE

PF20 bonding needles are normally used in Manual Thermocompression Bonders. They are mainly used in microwave applications where the bonding pads are too small to permit normal Ball and Stitch Bonding Techniques. Normally the wire is first positioned over the bonding pad area and then the bonding needle is used to make the bond. Wire diameters of .0010"/25 μ m or less are normally used in this application.



STANDARD DIMENSIONS		
Tip Diameter T in / μ m $\pm .0002/5$	Radius R in / μ m $\pm .0001/3$	Included Angle Δ
.0010 / 25	.0020 / 51	30 or 15
.0015 / 38	.0020 / 51	30 or 15
.0020 / 51	.0003 / 8	30 or 15

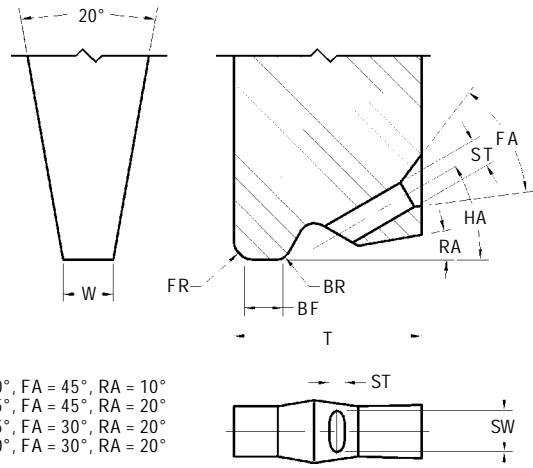
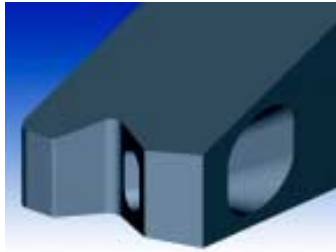
GENERAL GUIDELINES ON HOW TO ORDER PF NEEDLES

STYLE	
PF20 = PERIPHERAL NEEDLE (.0010"/25 μ m or less wire diameter)	

MATERIAL	BOND FLAT	TOOL LENGTH (TL)
W Tungsten Carbide Ultra Fine Grain for Aluminum Wire	Will rely on specific application requirements (wire diameter used, bond pad size) – see dimension Table	1" = 1.000" / 25.4 μ m 1/2" = .500" / 12.7 μ m

HOW TO ORDER	
SPECIFY	Style – Length – Tip Diameter (T) – Radius (R) - Included Angle (°)
EXAMPLE	PF20 - 1" - .0020 - .0003 - 30° PF20 - 1/2" - .0015 - .0002 - 30°

RIBBON WIRE BONDING TOOLS



RW30 HA = 30°, FA = 45°, RA = 10°
 RW45 HA = 45°, FA = 45°, RA = 20°
 RW55 HA = 55°, FA = 30°, RA = 20°
 RW60 HA = 60°, FA = 30°, RA = 20°

STANDARD DIMENSIONS

Tool Styles	Slot Width/Bond Flat SW / BF	Ribbon Width RW	Ribbon Thickness RT	Slot Width SW	Slot Thickness ST	Bond Foot BF	Foot Width W	Clearance 30° & 45° Slots C	Clearance 55° Slots C	Tip Thickness 30° Slots T	Tip Thickness 45° Slots T	Tip Thickness 55°/60° Slots T
		in / μm Ref	in / μm Ref	in / μm ±.0003/8	in / μm ±.0003/8	in / μm ±.0002/5	in / μm ±.0002/5	in / μm Ref	in / μm Ref	in / μm ±.0005/13	in / μm ±.0005/13	in / μm ±.0005/13
0420*		.0020 / 51	.0005 / 13	.0040 / 102	.0025 / 64	.0020 / 51	.0055 / 140	.0020 / 51	.0030 / 76	.0160 / 406	.0140 / 356	.0120 / 305
0425		.0020 / 51	to	.0040 / 102	.0025 / 64	.0020 / 51	.0055 / 140	.0020 / 51	.0030 / 76	.0160 / 406	.0140 / 356	.0120 / 305
0430		.0020 / 51	.0010 / 25	.0040 / 102	.0025 / 64	.0020 / 51	.0055 / 140	.0020 / 51	.0030 / 76	.0160 / 406	.0140 / 356	.0120 / 305
0520		.0030 / 76		.0050 / 127	.0025 / 64	.0020 / 51	.0065 / 165	.0020 / 51	.0030 / 76	.0160 / 406	.0140 / 356	.0120 / 305
0525*		.0030 / 76		.0050 / 127	.0025 / 64	.0025 / 64	.0065 / 165	.0020 / 51	.0030 / 76	.0160 / 406	.0140 / 356	.0120 / 305
0530		.0030 / 76		.0050 / 127	.0025 / 64	.0030 / 76	.0065 / 165	.0020 / 51	.0030 / 76	.0180 / 457	.0150 / 381	.0140 / 356
0540		.0030 / 76	.0005 / 13	.0050 / 127	.0025 / 64	.0040 / 102	.0065 / 165	.0020 / 51	.0030 / 76	.0180 / 457	.0150 / 381	.0140 / 356
0620		.0040 / 102	to	.0060 / 152	.0025 / 64	.0020 / 51	.0075 / 191	.0020 / 51	.0030 / 76	.0160 / 406	.0140 / 356	.0120 / 305
0625		.0040 / 102	.0010 / 25	.0060 / 152	.0025 / 64	.0025 / 64	.0075 / 191	.0020 / 51	.0030 / 76	.0160 / 406	.0140 / 356	.0120 / 305
0630*		.0040 / 102		.0060 / 152	.0025 / 64	.0030 / 76	.0075 / 191	.0020 / 51	.0030 / 76	.0160 / 406	.0150 / 381	.0140 / 356
0640		.0040 / 102		.0060 / 152	.0025 / 64	.0040 / 102	.0075 / 191	.0020 / 51	.0030 / 76	.0160 / 406	.0150 / 381	.0140 / 356
0725		.0050 / 127		.0070 / 178	.0030 / 76	.0025 / 64	.0085 / 216	.0025 / 64	.0040 / 102	.0210 / 533	.0180 / 457	.0140 / 356
0730		.0050 / 127		.0070 / 178	.0030 / 76	.0030 / 76	.0085 / 216	.0025 / 64	.0040 / 102	.0210 / 533	.0180 / 457	.0140 / 356
0740		.0050 / 127	.0005 / 13	.0070 / 178	.0030 / 76	.0040 / 102	.0085 / 216	.0025 / 64	.0040 / 102	.0210 / 533	.0180 / 457	.0160 / 406
0750		.0050 / 127	to	.0070 / 178	.0030 / 76	.0050 / 127	.0085 / 216	.0025 / 64	.0040 / 102	.0210 / 533	.0180 / 457	.0160 / 406
1125		.0070 / 178	.0020 / 51	.0110 / 279	.0030 / 76	.0025 / 64	.0125 / 318	.0025 / 64	.0040 / 102	.0210 / 533	.0180 / 457	.0160 / 406
1130		.0070 / 178		.0110 / 279	.0030 / 76	.0030 / 76	.0125 / 318	.0025 / 64	.0040 / 102	.0210 / 533	.0180 / 457	.0160 / 406
1140*		.0070 / 178		.0110 / 279	.0030 / 76	.0040 / 102	.0125 / 318	.0025 / 64	.0040 / 102	.0210 / 533	.0180 / 457	.0160 / 406
SW / BF	Ref	Ref	Ref	±.0005/13	±.0003/8	±.0002/5	±.0005/13	Ref	Ref	±.0005/13	±.0005/13	±.0005/13
1425		.0100 / 254		.0140 / 356	.0030 / 76	.0025 / 64	.0155 / 394	.0025 / 64	.0040 / 102	.0210 / 533	.0180 / 457	.0140 / 356
1430		.0100 / 254		.0140 / 356	.0030 / 76	.0030 / 76	.0155 / 394	.0025 / 64	.0040 / 102	.0210 / 533	.0180 / 457	.0140 / 356
1440		.0100 / 254		.0140 / 356	.0030 / 76	.0040 / 102	.0155 / 394	.0025 / 64	.0040 / 102	.0210 / 533	.0180 / 457	.0140 / 356
1625		.0120 / 305		.0160 / 406	.0030 / 76	.0025 / 64	.0175 / 445	.0025 / 64	.0040 / 102	.0210 / 533	.0180 / 457	.0140 / 356
1630		.0120 / 305		.0160 / 406	.0030 / 76	.0030 / 76	.0175 / 445	.0025 / 64	.0040 / 102	.0210 / 533	.0180 / 457	.0140 / 356
1640*		.0120 / 305	.0005 / 13	.0160 / 406	.0030 / 76	.0040 / 102	.0175 / 445	.0025 / 64	.0040 / 102	.0210 / 533	.0180 / 457	.0160 / 406
1650		.0120 / 305	to	.0160 / 406	.0030 / 76	.0050 / 127	.0175 / 445	.0025 / 64	.0040 / 102	.0210 / 533	.0180 / 457	.0160 / 406
1925		.0150 / 381	.0020 / 51	.0190 / 483	.0030 / 76	.0025 / 64	.0205 / 521	.0025 / 64	.0040 / 102	.0210 / 533	.0180 / 457	.0140 / 356
1930		.0150 / 381		.0190 / 483	.0030 / 76	.0030 / 76	.0205 / 521	.0025 / 64	.0040 / 102	.0210 / 533	.0180 / 457	.0140 / 356
1940*		.0150 / 381		.0190 / 483	.0030 / 76	.0040 / 102	.0205 / 521	.0025 / 64	.0040 / 102	.0210 / 533	.0180 / 457	.0160 / 406
2425		.0200 / 508		.0240 / 610	.0030 / 76	.0025 / 64	.0255 / 648	.0025 / 64	.0040 / 102	.0210 / 533	.0180 / 457	.0140 / 356
2430		.0200 / 508		.0240 / 610	.0030 / 76	.0030 / 76	.0255 / 648	.0025 / 64	.0040 / 102	.0210 / 533	.0180 / 457	.0140 / 356
2440		.0200 / 508		.0240 / 610	.0030 / 76	.0040 / 102	.0255 / 648	.0025 / 64	.0040 / 102	.0210 / 533	.0180 / 457	.0160 / 406
2450*		.0200 / 508		.0240 / 610	.0030 / 76	.0050 / 127	.0255 / 648	.0025 / 64	.0040 / 102	.0210 / 533	.0180 / 457	.0160 / 406

- * Most commonly specified
- Standard FR and BR : FR = .0010" / 25μm and BR = .0003" / 8μm is standard.
- Max Ribbon size for a vertical shank (1/16) is .012" / 305μm ribbon.

RIBBON WIRE TOOLS - GENERAL GUIDELINES ON HOW TO ORDER

STYLE		FEED ANGLE
RW = RIBBON WIRE	SLIMLINE BACK	30°, 45°, 55°, 60°

	MATERIAL	HOLE / BOND FLAT	TOOL LENGTH (TL)
C	Cermet composite for Gold Wire (recommended for Low Temperature bonding)	Will rely on specific application requirements (wire diameter used, bond pad size) – see dimension Table	S = .437 / 11.1 mm
TI	Titanium Carbide Composite for Gold Wire		¾ = .750 / 19.05 mm
W	Tungsten Carbide Ultra Fine Grain for Aluminum Wire		L = .828 / 21.0 mm 1.00 = 1.00 / 25.4 mm Longer lengths are available consult Bonder manufacturer for specifications.

FOOT OPTIONS	
FM	Flat foot design with the FR, BR and BF matte. (Standard)
CGM	Cross Groove with the FR and BR matte. Not recommended for BF smaller than .0020"/50µm

HOW TO ORDER	
SPECIFY	Style – Material – Tool Diameter – Tool Length – Foot Design
EXAMPLE	RW45 - TI - 1140 - 1/16 - L - CGM RW45 - TI - 0530 - 1/16 - L - FM

LARGE WIRE BONDING TOOLS

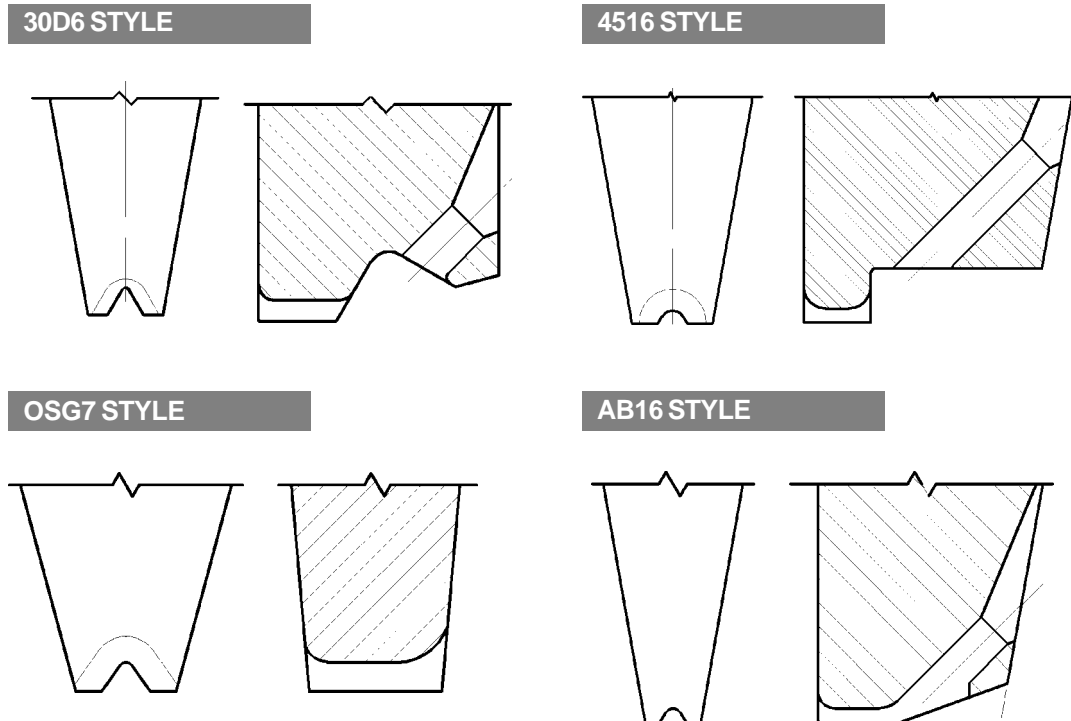
Large Wire Bonding is defined as wire diameters in the range of .003"/75µm to .020"/500µm. Tools designed to bond .003" wire diameter will bond 75µm wire diameters equally well.

Wire material most commonly used is 99.99% aluminum however, aluminum-magnesium (AlMg) is also used. The choice of aluminum wire used depends largely on the material being bonded to (die pad metallization). The AlMg wire material is much harder than pure aluminum. Materials of approximately the same hardness bond together best. That is, if the die metallization is soft, then the softer pure aluminum wire will form a weldment easier than the harder AlMg. If the metallization is harder then the AlMg wire material will work best. Many times the metallization of the die is soft and the metallization of the lead is hard...making the wire material optimum for one area and opposite for the other bonding target. If one is having a weldment problem with one particular metallization (die / lead) it is good to keep in mind the hardness differences between the two targets can help you to pinpoint the cause of the bonding issues. In most cases, however, the wire composition is specified for the product and the bond engineer has no choice as to whether 99.9% Al or AlMg can be used.

There are four basic types of large wire tools geometry, and Groove designs most commonly used for wire bonding. These designs overtime have been driven through the collaboration between the OEM and customer. The designs overtime have been the standards for the industry. The tool geometry are dedicated to a particular wirebonder. Groove designs, bond lengths are commonly driven by the customer requirements.

TOOL GEOMETRY

There are 4 basic types of large wire tool geometry. They include notch tools, L-notch tools, AutoBonding tools®, and No-hole tools.

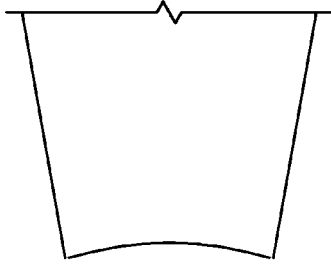


The No-hole style tools require a separate wire feed guide which guides the wire just behind the tool, and travels in unison with the tools movement. All other types of tools have an integrated wire feed hole at various angles to the bond plane. The bonding machine being used determines the tool design that is chosen. AutoBonding Tools® help guide the wire directly under the foot this design is commonly used where L-notch tools experience wire control problems where different bonding heights and extreme long wires are bonded.

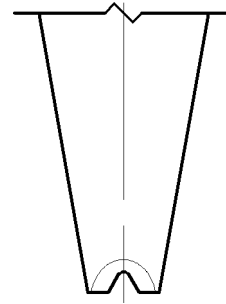
GROOVE DESIGNS

There are 5 different styles of groove designs. They include Concave, Inline groove, "V" groove, Deep "V" groove and "U" groove designs

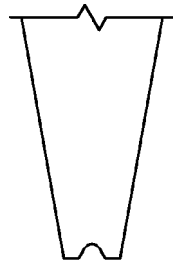
1009A CONCAVE FOOT STYLE



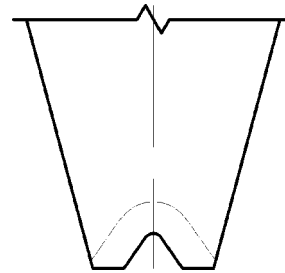
1016A INLINE GROOVE STYLE



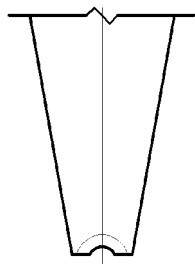
AB16 V GROOVE STYLE



OSG7 DEEP V GROOVE STYLE



1015A U GROOVE STYLE



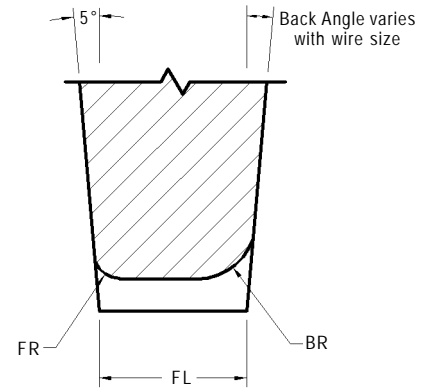
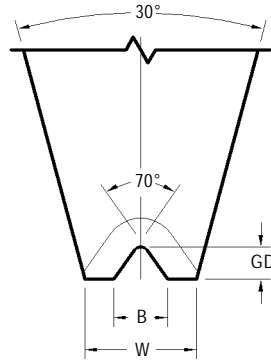
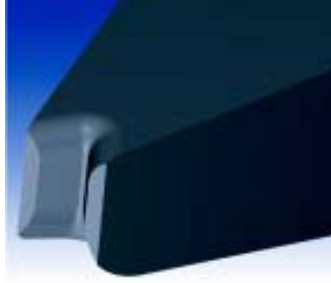
The evolution of the groove designs have evolved by necessity due to the progress made in the development of better materials for bonding, Mold compounds, improved lead frame designs to minimize package delamination, faster bonders and the shrinkage of real-estate to bond to has pushed the tool design to more of a "V" groove type tool with no-hole allowing for bonding in tight conditions where other tools designs are becoming obsolete. Initially bigger bonds were considered to be more reliable but basically were used as a band-aid to compensate for the inequities of the materials.

The integration of power and logic (SmartMos®) has set new standards for bonding large wire. The package, silicon, and pad size has shrunk by 25 to 30% in some cases pushing the design rules to its limit.

For special bonding requirements contact the factory for designs and availability.

INLINE GROOVE NO-HOLE TOOLS

OSG7 STYLE



STANDARD DIMENSIONS

Tool Styles - Wire Size	Useable Wire Diameter WD in / μm	Foot Length FL in / μm $\pm .0005/13$	Front Radius FR in / μm (Ref)	Back Radius BR in / μm (Ref)	Foot Width W in / μm $\pm .0005/13$	Groove Depth GD in / μm Min	Groove Opening B in / μm $\pm .0003/8$
OSG7-100	.0040 / 100	.0114 / 290	.0027 / 69	.0054 / 137	.0080 / 200	.0027 / 69	.0046 / 117
OSG7-125	.0050 / 125	.0142 / 361	.0034 / 86	.0068 / 173	.0100 / 254	.0034 / 86	.0057 / 145
OSG7-150	.0060 / 150	.0170 / 432	.0041 / 104	.0082 / 208	.0120 / 305	.0040 / 102	.0068 / 173
OSG7-175	.0070 / 175	.0199 / 505	.0048 / 122	.0096 / 244	.0140 / 356	.0048 / 122	.0080 / 203
OSG7-200	.0080 / 200	.0226 / 574	.0054 / 137	.0109 / 277	.0160 / 406	.0055 / 140	.0091 / 231
		$\pm .0005/13$	(Ref)	(Ref)	$\pm .0005/13$	Min (75%)	$\pm .0005/13$
OSG7-250	.0100 / 250	.0283 / 719	.0068 / 173	.0136 / 345	.0200 / 508	.0075 / 191	.0122 / 310
OSG7-300	.0120 / 300	.0340 / 864	.0082 / 208	.0163 / 414	.0240 / 610	.0090 / 229	.0146 / 371
OSG7-350	.0140 / 356	.0396 / 1006	.0095 / 241	.0190 / 483	.0280 / 711	.0105 / 267	.0171 / 434
OSG7-380	.0150 / 381	.0425 / 1080	.0102 / 259	.0204 / 518	.0300 / 762	.0113 / 287	.0183 / 465
OSG7-400	.0160 / 400	.0440 / 1118	.0106 / 269	.0211 / 536	.0320 / 813	.0118 / 300	.0195 / 495
OSG7-450	.0180 / 450	.0510 / 1295	.0122 / 310	.0245 / 622	.0363 / 922	.0140 / 356	.0220 / 559
OSG7-500	.0200 / 500	.0566 / 1438	.0136 / 345	.0272 / 691	.0400 / 1016	.0150 / 381	.0244 / 620

INLINE GROOVE NO-HOLE TOOLS - GENERAL GUIDELINES ON HOW TO ORDER

STYLE	WIRE SIZE	MATERIAL
OSG7 : 70° Deep "V" Groove	Specify Wire Size	W : Tungsten Carbide Ultra Fine Grain for Aluminum Wire

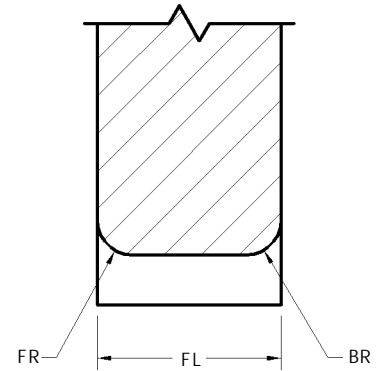
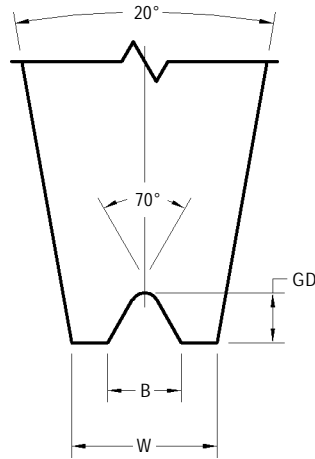
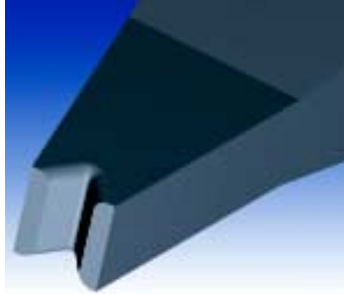
Tool Dia	TD in / mm ±.0001"/13µm	TDF in / mm ±.0005"/13µm	Specified Length	TL in / mm ±.005"/130µm
1/8	.1249 / 3.172	.0937 / 2.378	1.00	1.06 / 26.9
1/8	.1249 / 3.172	.110 / 2.794	64mm	2.505 / 63.63

FOOT OPTIONS	
G	The FR and BR are polished and a fine matte finish is within the area of the groove. (Standard)
GM	The FR, BR and groove have a matte finish

HOW TO ORDER	
SPECIFY	Style - Wire - Material - Tool Diameter - Tool Length - Foot Option (For modifications to standard tools, use part number and specify modified dimensions or contact our technical support staff for assistance with your requirements). For Shank Style refer to page 62.
EXAMPLE	OSG7 - 250 - W - 1/8 - 64mm - G OSG7 - 350 - W - 1/8 - 64mm - GM

INLINE GROOVE NO-HOLE TOOLS

CKVD STYLE



STANDARD DIMENSIONS

Tool Styles - Wire Size	Useable Wire Diameter WD in / μm	Foot Length FL in / μm $\pm .0003/8$	Front/Back Radius FR = BR in / μm (Ref)	Foot Width W in / μm $\pm .0003/8$	Groove Depth GD in / μm Min	Groove Opening B in / μm $\pm .0003/8$	Relief E in / μm $\pm .0039/100$
CKVD-100	.0040 / 100	.0098 / 250	.0012 / 30	.0079 / 200	.0028 / 71	.0043 / 109	.0390 / 1000
CKVD-125	.0050 / 125	.0118 / 300	.0015 / 38	.0098 / 250	.0035 / 89	.0054 / 137	.0390 / 1000
CKVD-150	.0060 / 150	.0138 / 350	.0018 / 45	.0118 / 300	.0042 / 107	.0065 / 165	.0390 / 1000
CKVD-175	.0070 / 175	.0157 / 400	.0021 / 53	.0138 / 350	.0049 / 124	.0076 / 193	.0390 / 1000
CKVD-200	.0080 / 200	.0177 / 450	.0024 / 61	.0157 / 400	.0056 / 142	.0087 / 221	.0390 / 1000
		$\pm .0005/13$	(Ref)	$\pm .0005/13$	Min	$\pm .0005/13$	$\pm .0039/100$
CKVD-250	.0100 / 250	.0217 / 551	.0030 / 76	.0197 / 500	.0070 / 178	.0108 / 274	.0590 / 1500
CKVD-300	.0120 / 300	.0256 / 650	.0035 / 89	.0236 / 600	.0084 / 213	.0130 / 330	.0590 / 1500
CKVD-350	.0140 / 350	.0299 / 760	.0041 / 104	.0276 / 700	.0098 / 249	.0152 / 386	.0590 / 1500
CKVD-380	.0150 / 380	.0323 / 820	.0045 / 114	.0299 / 760	.0106 / 269	.0165 / 419	.0590 / 1500
CKVD-400	.0160 / 400	.0343 / 871	.0047 / 119	.0315 / 800	.0112 / 284	.0173 / 439	.0590 / 1500
CKVD-500	.0200 / 500	.0433 / 110	.0059 / 150	.0394 / 1000	.0140 / 356	.0217 / 551	.0590 / 1500

INLINE GROOVE NO-HOLE TOOLS - GENERAL GUIDELINES ON HOW TO ORDER

STYLE	WIRE SIZE	MATERIAL
CKVD : 70° Deep "V" Groove	Specify Wire Size	W : Tungsten Carbide Ultra Fine Grain for Aluminum Wire

Tool Dia	TD in / mm ±.0001"/3µm	TDF in / mm ±.0005"/13µm	Specified Length	TL in / mm ±.005"/130µm
1/16	.0624 / 1.585	.0570 / 1.448 *	L	.828 / 21.0
1/8	.1249 / 3.172	.0937 / 2.378 ***	1.00	1.000 / 25.4
2mm	.0785 / 1.995 @	.0630 / 1.600 *	20mm	.787 / 20.0
3mm	.1180 / 2.997	.0985 / 2.502 **	29mm	1.142 / 29.0

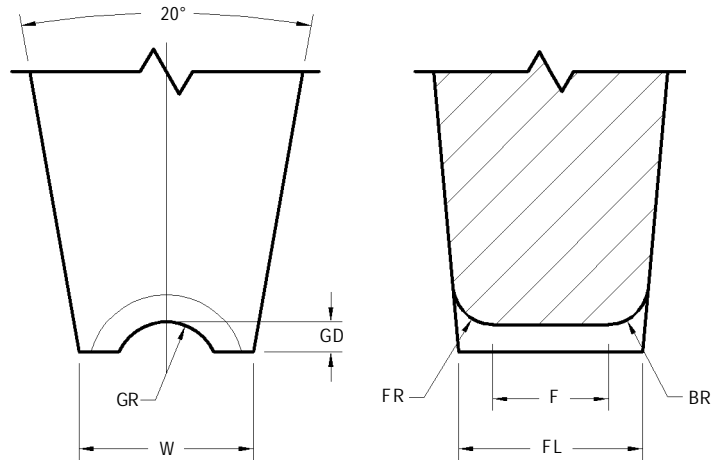
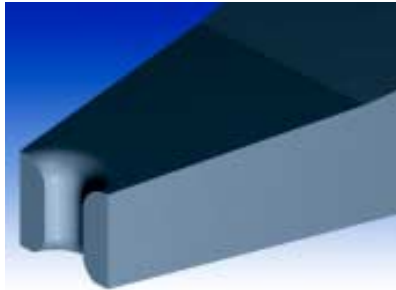
NOTE	
Length	29mm for Deep Access
*	limited size availability.
**	.110" / 2.79mm TDF supplied if required by foot geometry.
***	.1180" / 3.00mm TDF supplied if required by foot geometry.
@	Tolerance +0 / - .0002" / 5µm

FOOT OPTIONS	
G	The FR and BR are polished and a fine matte finish is within the area of the groove. (Standard)
GM	The FR, BR and groove have a matte finish

HOW TO ORDER	
SPECIFY	Style - Wire - Material - Tool Diameter - Tool Length - Foot Option (For modifications to standard tools, use part number and specify modified dimensions or contact our technical support staff for assistance with your requirements). For Shank Style refer to page 62.
EXAMPLE	CKVD - 250 - W - 2mm - 29mm - G

INLINE GROOVE NO-HOLE TOOLS

CK STYLE



STANDARD DIMENSIONS

Tool Styles - Wire Size	Useable Wire Diameter WD in / μm	Foot Length FL in / μm $\pm .0005/13$	Front/Back Radius FR = BR in / μm $\pm .0005/13$	Flat F in / μm (Ref)	Foot Width W in / μm $\pm .0005/13$	Groove Depth GD in / μm $\pm .0002/5$	Groove Radius GR in / μm $\pm .0002/5$
CK-75	.0030 / 75	.0065 / 165	.0018 / 46	.0030 / 76	.0075 / 191	.0010 / 25	.0018 / 46
CK-100	.0040 / 100	.0090 / 229	.0024 / 61	.0039 / 99	.0100 / 254	.0014 / 36	.0024 / 61
CK-125	.0050 / 125	.0110 / 279	.0030 / 76	.0049 / 124	.0120 / 305	.0017 / 43	.0030 / 76
CK-150	.0060 / 150	.0130 / 330	.0035 / 89	.0059 / 150	.0150 / 381	.0021 / 53	.0035 / 89
CK-175	.0070 / 175	.0150 / 381	.0041 / 104	.0069 / 175	.0170 / 432	.0024 / 61	.0041 / 104
CK-200	.0080 / 200	.0170 / 432	.0047 / 119	.0079 / 201	.0200 / 508	.0028 / 71	.0047 / 119

INLINE GROOVE NO-HOLE TOOLS - GENERAL GUIDELINES ON HOW TO ORDER

STYLE	WIRE SIZE	MATERIAL
CK : Inline Groove	Specify Wire Size	W : Tungsten Carbide Ultra Fine Grain for Aluminum Wire

Tool Dia	TD in / mm ±.0001"/3µm	TDF in / mm ±.0005"/13µm	Specified Length	TL in / mm ±.005"/130µm
1/16	.0624 / 1.585	.0570 / 1.448 *	L	.828 / 21.0
1/8	.1249 / 3.172	.0937 / 2.378 ***	1.00	1.000 / 25.4
2mm	.0785 / 1.995 @	.0630 / 1.600 *	20mm	.787 / 20.0
3mm	.1180 / 2.997	.0985 / 2.502 **	29mm	1.142 / 29.0

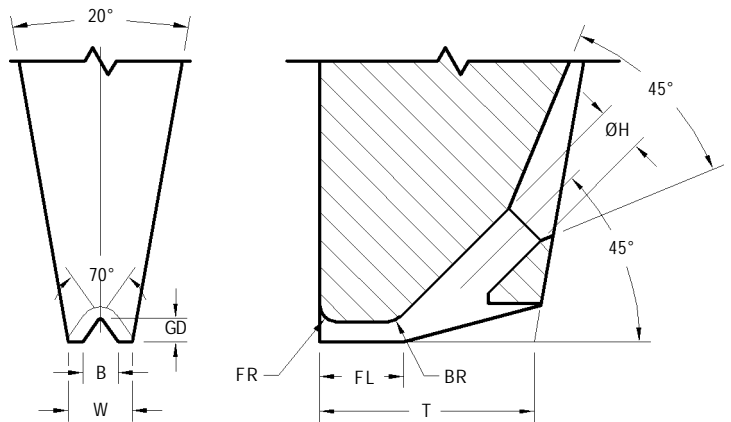
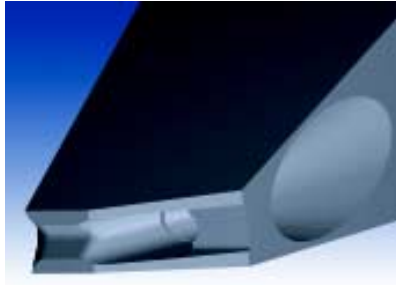
NOTE	
*	limited size availability.
**	.110" / 2.79mm TDF supplied if required by foot geometry.
***	.1180" / 3.00mm TDF supplied if required by foot geometry.
@	Tolerance +0 / - .0002" / 5µm

FOOT OPTIONS	
G	The FR and BR are polished and a fine matte finish is within the area of the groove. (Standard)
GM	The FR, BR and groove have a matte finish

HOW TO ORDER	
SPECIFY	Style - Wire - Material - Tool Diameter - Tool Length - Foot Option (For modifications to standard tools, use part number and specify modified dimensions or contact our technical support staff for assistance with your requirements). For Shank Style refer to page 62.
EXAMPLE	CK - 200 - W - 2mm - 29mm - G CK - 150 - W - 2mm - 29mm - GM CK - 200 - W - 3mm - 20mm - G

INLINE GROOVE AUTOBONDING TOOLS

45CK STYLE



STANDARD DIMENSIONS

Tool Styles - Wire Size	Useable Wire Diameter WD in / μm	Hole Diameter in / μm $\pm .0005/13$	Foot Length FL in / μm $\pm .0005/13$	Front/Back Radius FR = BR in / μm (Ref)	Foot Width W in / μm $\pm .0005/13$	Tip Length T in / μm $\pm .0010/25$	Groove Depth GD in / μm Min	Groove Opening B in / μm $\pm .0003/18$
45CK-75	.0030 / 75	.0055 / 140	.0070 / 178	.0015 / 38	.0070 / 178	.0270 / 686	.0018 / 46	.0032 / 81
45CK-100	.0040 / 100	.0059 / 150	.0073 / 185	.0020 / 51	.0079 / 200	.0290 / 737	.0026 / 65	.0043 / 110
45CK-125	.0050 / 125	.0074 / 188	.0086 / 219	.0025 / 64	.0098 / 250	.0340 / 864	.0032 / 81	.0054 / 137
45CK-150	.0060 / 150	.0089 / 226	.0100 / 254	.0030 / 76	.0118 / 300	.0400 / 1016	.0038 / 97	.0065 / 165
45CK-175	.0070 / 175	.0103 / 262	.0105 / 267	.0035 / 89	.0138 / 350	.0470 / 1194	.0045 / 114	.0076 / 193
45CK-200	.0080 / 200	.0118 / 300	.0106 / 270	.0039 / 100	.0157 / 400	.0540 / 1372	.0051 / 130	.0087 / 221
		$\pm .0005/13$	$\pm .0005/13$	(Ref)	$\pm .0005/13$	$\pm .0010/25$	Min	$\pm .0005/13$
45CK-250	.0100 / 250	.0148 / 376	.0133 / 338	.0046 / 125	.0197 / 500	.0063 / 1600	.0064 / 163	.0108 / 274

INLINE GROOVE AUTOBONDING TOOLS - GENERAL GUIDELINES ON HOW TO ORDER

STYLE	FEED ANGLE
45CK : Inline and 70° "V" Groove	45° 60° wire feed available with slimline

WIRE SIZE	MATERIAL
Specify Wire Size	W : Tungsten Carbide Ultra Fine Grain for Aluminum Wire

Tool Dia	TD in / mm ±.0001"/13µm	TDF in / mm ±.0005"/13µm	Specified Length	TL in / mm ±.005"/130µm
1/16	.0624 / 1.585	.0570 / 1.448 *	L	.828 / 21.0
1/8	.1249 / 3.172	.0937 / 2.378 ***	1.00	1.000 / 25.4
2mm	.0785 / 1.995 @	.0630 / 1.600 *	20mm	.787 / 20.0
3mm	.1180 / 2.997	.0985 / 2.502 **	29mm	1.142 / 29.0

NOTE	
*	limited size availability.
**	.110" / 2.79mm TDF supplied if required by foot geometry.
***	.1180" / 3.00mm TDF supplied if required by foot geometry.
@	Tolerance +0 / - .0002" / 5µm

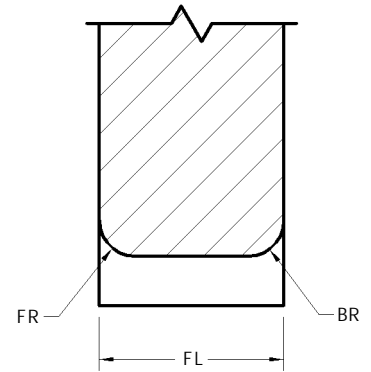
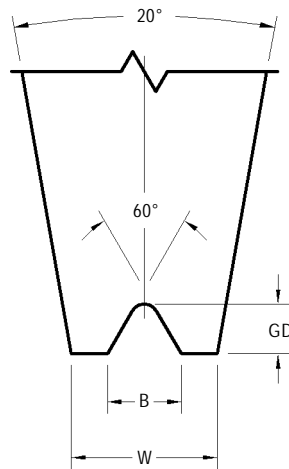
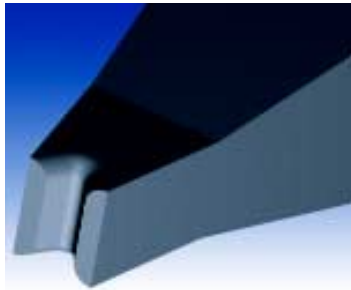
FOOT OPTIONS	
G	The FR and BR are polished and a fine matte finish is within the area of the groove. (Standard)
GM	The FR, BR and groove have a matte finish

HOW TO ORDER	
SPECIFY	Style - Wire - Material - Tool Diameter - Tool Length - Foot Option (For modifications to standard tools, use part number and specify modified dimensions or contact our technical support staff for assistance with your requirements). For Shank Style refer to page 62.
EXAMPLE	45CK - 200 - W - 2mm - 29mm - G

LARGE WIRE
BONDING TOOLS

INLINE GROOVE NO-HOLE TOOLS

LWD6 STYLE



STANDARD DIMENSIONS

Tool Styles - Wire Size	Useable Wire Diameter WD in / μm	Foot Length FL in / μm $\pm .0003/8$	Front/Back Radius FR = BR in / μm (Ref)	Foot Width W in / μm $\pm .0003/8$	Groove Depth GD in / μm Min	Groove Opening B in / μm $\pm .0003/8$	Relief E in / μm $\pm .010/254$ -0
LWD6-75	.0030 / 75	.0080 / 203	.0015 / 38	.0075 / 191	.0021 / 53	.0033 / 84	.0200 / 508
LWD6-100	.0040 / 100	.0105 / 267	.0020 / 51	.0100 / 254	.0028 / 71	.0044 / 112	.0200 / 508
LWD6-125	.0050 / 125	.0130 / 330	.0025 / 64	.0120 / 305	.0035 / 89	.0055 / 140	.0200 / 508
LWD6-150	.0060 / 150	.0155 / 394	.0030 / 76	.0140 / 356	.0042 / 107	.0066 / 168	.0200 / 508
LWD6-175	.0070 / 175	.0180 / 457	.0035 / 89	.0155 / 394	.0049 / 124	.0077 / 196	.0200 / 508
LWD6-200	.0080 / 200	.0205 / 521	.0040 / 102	.0175 / 445	.0056 / 142	.0088 / 224	.0200 / 508
		$\pm .0005/13$	(Ref)	$\pm .0005/13$	Min	$\pm .0005/13$	$\pm .010/254$ -0
LWD6-250	.0100 / 250	.0270 / 686	.0050 / 127	.0215 / 546	.0070 / 178	.0110 / 279	.0400 / 1016
LWD6-300	.0120 / 300	.0305 / 775	.0060 / 152	.0255 / 648	.0084 / 213	.0132 / 335	.0400 / 1016
LWD6-350	.0140 / 350	.0330 / 838	.0070 / 178	.0295 / 749	.0098 / 249	.0154 / 391	.0400 / 1016
LWD6-380	.0150 / 380	.0345 / 876	.0075 / 191	.0315 / 800	.0105 / 267	.0165 / 419	.0600 / 1524
LWD6-400	.0160 / 400	.0355 / 902	.0080 / 203	.0335 / 851	.0112 / 284	.0176 / 447	.0600 / 1524
LWD6-500	.0200 / 500	.0445 / 1130	.0100 / 254	.0415 / 1054	.0140 / 356	.0220 / 559	.0600 / 1524

INLINE GROOVE NO-HOLE TOOLS - GENERAL GUIDELINES ON HOW TO ORDER

STYLE	WIRE SIZE	MATERIAL
LWD6 : 60° Deep "V" Groove	Specify Wire Size	W : Tungsten Carbide Ultra Fine Grain for Aluminum Wire

Tool Dia	TD in / mm ±.0001"/3µm	TDF in / mm ±.0005"/13µm	Specified Length	TL in / mm ±.005"/130µm
1/16	.0624 / 1.585	.0570 / 1.448 *	L	.828 / 21.0
1/8	.1249 / 3.172	.0937 / 2.378 ***	1.00	1.000 / 25.4
2mm	.0785 / 1.995 @	.0630 / 1.600 *	20mm	.787 / 20.0
3mm	.1180 / 2.997	.0985 / 2.502 **	30mm	1.181 / 30.0

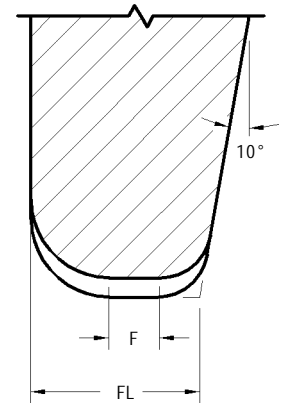
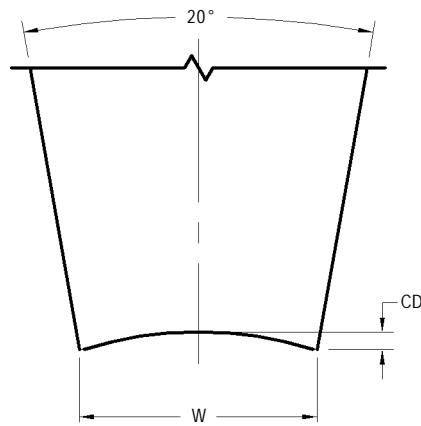
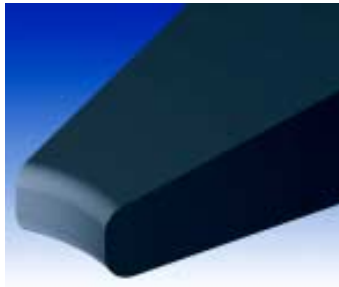
NOTE	
*	limited size availability.
**	.110" / 2.79mm TDF supplied if required by foot geometry.
***	.1180" / 3.00mm TDF supplied if required by foot geometry.
@	Tolerance +0 / - .0002" / 5µm

FOOT OPTIONS	
G	The FR and BR are polished and a fine matte finish is within the area of the groove. (Standard)
GM	The FR, BR and groove have a matte finish

HOW TO ORDER	
SPECIFY	Style - Wire - Material - Tool Diameter - Tool Length - Foot Option (For modifications to standard tools, use part number and specify modified dimensions or contact our technical support staff for assistance with your requirements). For Shank Style refer to page 62.
EXAMPLE	LWD6 - 250 - W - 1/8 - 1.00 - G LWD6 - 350 - W - 1/8 - 1.00 - G

CONCAVE NO-HOLE BONDING TOOLS

1009A STYLE



STANDARD DIMENSIONS

Tool Styles - Wire Size	Useable Wire Diameter WD in / μm	Foot Length FL in / μm $\pm .0005/13$	Front Radius FR in / μm $\pm .0005/13$	Back Radius BR in / μm $\pm .0003/8$	Flat F in / μm (Ref)	Foot Width W in / μm $\pm .0005/13$	Concave Depth CD in / μm $\pm .0002/5$
1009A-4	.0040 / 100	.0160 / 406	.0080 / 203	.0050 / 127	.0055 / 140	.0120 / 305	.0010 / 25
1009A-5	.0050 / 125	.0180 / 457	.0090 / 229	.0050 / 127	.0070 / 178	.0150 / 381	.0013 / 33
1009A-6	.0060 / 150	.0180 / 457	.0090 / 229	.0060 / 152	.0065 / 165	.0180 / 457	.0016 / 41
1009A-7	.0070 / 175	.0180 / 457	.0090 / 229	.0060 / 152	.0065 / 165	.0210 / 533	.0018 / 46
1009A-8	.0080 / 200	.0180 / 457	.0090 / 229	.0060 / 152	.0065 / 165	.0240 / 610	.0020 / 51

CONCAVE NO HOLE TOOLS - GENERAL GUIDELINES ON HOW TO ORDER

STYLE	WIRE SIZE	MATERIAL
1009A : Concave No-Hole	Specify Wire Size	W : Tungsten Carbide Ultra Fine Grain for Aluminum Wire

Tool Dia	TD in / mm ±.0001"/3µm	TDF in / mm ±.0005"/13µm	Specified Length	TL in / mm ±.005"/130µm
1/16	.0624 / 1.585	.0570 / 1.448 *	L	.828 / 21.0
1/8	.1249 / 3.172	.0937 / 2.378 ***	1.00	1.000 / 25.4
2mm	.0785 / 1.995 @	.0630 / 1.600 *	20mm	.787 / 20.0
3mm	.1180 / 2.997	.0985 / 2.502 **	29mm	1.142 / 29.0

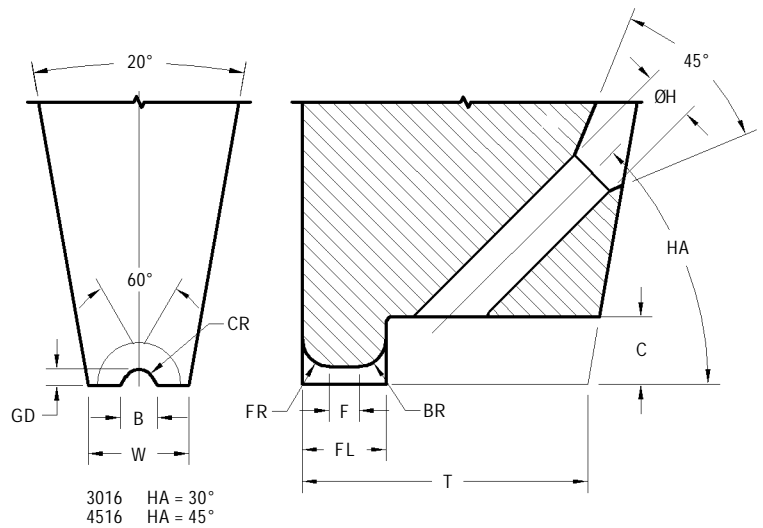
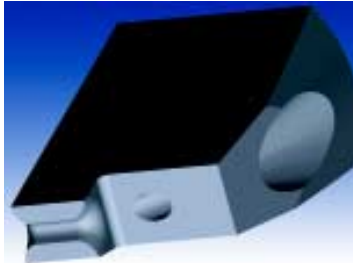
NOTE	
*	limited size availability.
**	.110" / 2.79mm TDF supplied if required by foot geometry.
***	.1180" / 3.00mm TDF supplied if required by foot geometry.
@	Tolerance +0 / - .0002" / 5µm

FOOT OPTIONS	
C	The FR and BR are polished and a fine matte finish is within the area of the groove. (Standard)
CM	The FR, BR and groove have a matte finish

HOW TO ORDER	
SPECIFY	Style - Wire - Material - Tool Diameter - Tool Length - Foot Option (For modifications to standard tools, use part number and specify modified dimensions or contact our technical support staff for assistance with your requirements). For Shank Style refer to page 62.
EXAMPLE	1009A - 5 - W - 3mm - L - CM 1009A - 8 - W - 1/8 - L - C

LARGE WIRE INLINE GROOVE NOTCH TOOLS

3016 / 4516 STYLE



STANDARD DIMENSIONS

Tool Styles	Useable Wire Diameter WD in / μm	4516 / 3016 Hole Dia H in / μm $\pm .0002/5$	Foot Length FL in / μm $\pm .0005/13$	Front Radius FR in / μm $\pm .0005/13$	Back Radius BR in / μm $\pm .0005/13$	Flat F in / μm (Ref)	4516 / 3016 Foot Width W in / μm $\pm .0002/5$	4516 / 3016 Clearance C in / μm (Ref)	4516 Series Tip Length T in / μm $\pm .0010/25$	3016 Series Tip Length T in / μm $\pm .0010/25$
3S	.0030 / 75	.0045 / 114	.0085 / 216	.0024 / 61	.0036 / 91	.0025 / 64	.0090 / 229	.0080 / 203	.0270 / 686	.0300 / 762
3R	.0030 / 75	.0045 / 114	.0095 / 241	.0024 / 61	.0036 / 91	.0035 / 89	.0090 / 229	.0080 / 203	.0280 / 711	.0310 / 787
3XL	.0030 / 75	.0045 / 114	.0120 / 305	.0024 / 61	.0036 / 91	.0060 / 152	.0090 / 229	.0080 / 203	.0300 / 762	.0330 / 838
4S	.0040 / 100	.0060 / 152	.0110 / 279	.0032 / 81	.0048 / 122	.0030 / 76	.0120 / 305	.0100 / 254	.0350 / 889	.0390 / 991
4R	.0040 / 100	.0060 / 152	.0130 / 330	.0032 / 81	.0048 / 122	.0050 / 127	.0120 / 305	.0100 / 254	.0370 / 940	.0410 / 1041
4XL	.0040 / 100	.0060 / 152	.0160 / 406	.0032 / 81	.0048 / 122	.0080 / 203	.0120 / 305	.0100 / 254	.0400 / 1016	.0440 / 1118
5S	.0050 / 125	.0075 / 191	.0140 / 356	.0040 / 102	.0060 / 152	.0040 / 102	.0150 / 381	.0115 / 292	.0440 / 1118	.0490 / 1245
5R	.0050 / 125	.0075 / 191	.0160 / 406	.0040 / 102	.0060 / 152	.0600 / 152	.0150 / 381	.0115 / 292	.0460 / 1168	.0510 / 1295
5XL	.0050 / 125	.0075 / 191	.0200 / 508	.0040 / 102	.0060 / 152	.0100 / 254	.0150 / 381	.0115 / 292	.0500 / 1270	.0550 / 1397
6S	.0060 / 150	.0090 / 229	.0170 / 432	.0048 / 122	.0072 / 183	.0050 / 127	.0180 / 457	.0135 / 343	.0530 / 1346	.0590 / 1499
6R	.0060 / 150	.0090 / 229	.0190 / 483	.0048 / 122	.0072 / 183	.0070 / 178	.0180 / 457	.0135 / 343	.0550 / 1397	.0610 / 1549
6XL	.0060 / 150	.0090 / 229	.0240 / 610	.0048 / 122	.0072 / 183	.0120 / 305	.0180 / 457	.0135 / 343	.0600 / 1524	.0660 / 1676
8S	.0080 / 200	.0120 / 305	.0225 / 572	.0064 / 163	.0096 / 244	.0065 / 165	.0240 / 610	.0170 / 432	.0710 / 1803	.0790 / 2007
8R	.0080 / 200	.0120 / 305	.0255 / 648	.0064 / 163	.0096 / 244	.0095 / 241	.0240 / 610	.0170 / 432	.0740 / 1880	.0820 / 2083
8XL	.0080 / 200	.0120 / 305	.0320 / 813	.0064 / 163	.0096 / 244	.0160 / 406	.0240 / 610	.0170 / 432	.0800 / 2032	.0880 / 2235
		$\pm .0005/13$	$\pm .0005/13$	$\pm .0010/25$	$\pm .0010/25$	(Ref)	$\pm .0010/25$	(Ref)	$\pm .0010/25$	
10S	.0100 / 250	.0150 / 381	.0280 / 711	.0080 / 203	.0120 / 305	.0080 / 203	.0300 / 762	.0200 / 508	.0880 / 2235	
10L	.0100 / 250	.0150 / 381	.0350 / 889	.0080 / 203	.0120 / 305	.0150 / 381	.0300 / 762	.0200 / 508	.0950 / 2413	
10XL	.0100 / 250	.0150 / 381	.0400 / 1016	.0080 / 203	.0120 / 305	.0200 / 508	.0300 / 762	.0200 / 508	.1000 / 2540	
12S	.0120 / 300	.0180 / 457	.0335 / 851	.0095 / 241	.0145 / 368	.0095 / 241	.0360 / 914	.0240 / 610	.1060 / 2692	
12R	.0120 / 300	.0180 / 457	.0385 / 978	.0095 / 241	.0145 / 368	.0143 / 363	.0360 / 914	.0240 / 610	.1100 / 2794	
14S	.0140 / 350	.0210 / 533	.0390 / 991	.0110 / 279	.0170 / 432	.0110 / 279	.0420 / 1067	.0280 / 711	.1100 / 2794	Not available
14R	.0140 / 350	.0210 / 533	.0367 / 932	.0085 / 216	.0170 / 432	.0200 / 508	.0420 / 1067	.0200 / 508	.1100 / 2794	Not available
15S	.0150 / 380	.0225 / 572	.0330 / 838	.0090 / 229	.0090 / 229	.0150 / 381	.0450 / 1143	.0210 / 533	.1100 / 2794	
15R	.0150 / 380	.0225 / 572	.0390 / 991	.0090 / 229	.0090 / 229	.0210 / 533	.0450 / 1143	.0210 / 533	.1100 / 2794	
16S	.0160 / 400	.0240 / 610	.0352 / 894	.0095 / 241	.0095 / 241	.0165 / 419	.0480 / 1219	.0220 / 559	.1100 / 2794	
20XS	.0200 / 500	.0240 / 610	.0310 / 787	.0095 / 241	.0095 / 241	.0110 / 279	.0600 / 1524	.0260 / 660	.1100 / 2794	

INLINE GROOVE NOTCH TOOLS - GENERAL GUIDELINES ON HOW TO ORDER

STYLE		FEED ANGLE
3016 4516	Inline and 60° "V" Groove	30° 45° 60° wire feed available with slimline

WIRE SIZE	MATERIAL
Specify Wire Size	W: Tungsten Carbide Ultra Fine Grain for Aluminum Wire

Tool Dia	TD in / mm ±.0001"/3µm	TDF in / mm ±.0005"/13µm	Specified Length	TL in / mm ±.005"/130µm
1/16	.0624 / 1.585	.0570 / 1.448 *	3/4	.750 / 19.05
1/8	.1249 / 3.172	.0937 / 2.378 ***	L	.828 / 21.0
2mm	.0785 / 1.995 @	.0630 / 1.600 *	1.00	1.000 / 25.4
3mm	.1180 / 2.997	.0985 / 2.502 **	30mm	1.181 / 30.0

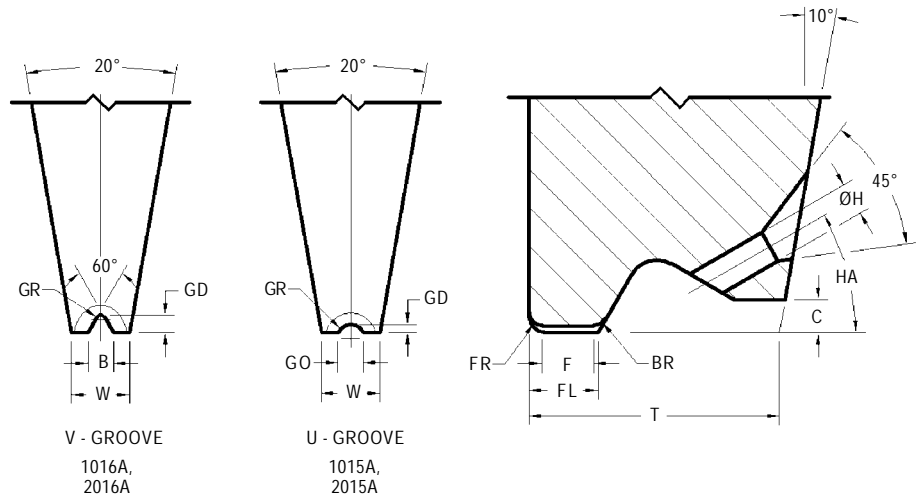
NOTE	
*	limited size availability.
**	.110" / 2.79mm TDF supplied if required by foot geometry.
***	.1180" / 3.00mm TDF supplied if required by foot geometry.
@	Tolerance +0 / - .0002" / 5µm

FOOT OPTIONS	
G	The FR and BR are polished and a fine matte finish is within the area of the groove. (Standard)
GM	The FR, BR and groove have a matte finish GD = 40% to 60% of wire diameter

HOW TO ORDER	
SPECIFY	Style - Wire / Foot Size - Material - Tool Diameter - Tool Length - Foot Option (For modifications to standard tools, use part number and specify modified dimensions or contact our technical support staff for assistance with your requirements). For Shank Style refer to page 62.
EXAMPLE	4516 - 5R - W - 3mm - L - GM 4516 - 8XL - W - 1/8 - L - G 3016 - 12R - W - 1/8 - 1.00 - GM

INLINE GROOVE NOTCH TOOLS

1015A, 2015A / 1016A, 2016A STYLE



1015A, 1016A HA = 30°
 2015A, 2016A HA = 45°

STANDARD DIMENSIONS

Tool Styles	Useable Wire Diameter WD in / μm	Hole Diameter H in / μm $\pm .0005/13$	Foot Length FL in / μm $\pm .0005/13$	Front Radius FR in / μm $\pm .0005/13$	Back Radius BR in / μm $\pm .0005/13$	Flat F in / μm (Ref)	Foot Width W in / μm $\pm .0005/13$	Clearance C in / μm (Ref)	Tip Length T in / μm $\pm .0010/25$	Groove Depth GD in / μm $\pm .0002/5$	Groove Opening GO in / μm $\pm .0005/13$
1015A 2015A	.0030 / 75	.0045 / 114	.0090 / 229	.0018 / 46	.0018 / 46	.0065 / 165	.0075 / 191	.0040 / 102	.0350 / 889	.0009 / 23	.0032 / 81
	.0040 / 100	.0060 / 152	.0120 / 305	.0024 / 61	.0024 / 61	.0090 / 229	.0100 / 254	.0040 / 102	.0400 / 1016	.0012 / 30	.0042 / 107
	.0050 / 125	.0075 / 191	.0150 / 381	.0030 / 76	.0030 / 76	.0110 / 279	.0125 / 318	.0040 / 102	.0450 / 1143	.0015 / 38	.0053 / 135
	.0060 / 150	.0900 / 229	.0180 / 457	.0036 / 91	.0036 / 91	.0135 / 343	.0150 / 381	.0040 / 102	.0500 / 1270	.0018 / 46	.0063 / 160
	.0070 / 175	.0105 / 267	.0210 / 533	.0042 / 107	.0042 / 107	.0155 / 394	.0175 / 445	.0040 / 102	.0570 / 1448	.0020 / 51	.0071 / 180
	.0080 / 200	.0120 / 305	.0210 / 533	.0048 / 122	.0048 / 122	.0150 / 381	.0200 / 508	.0040 / 102	.0570 / 1448	.0024 / 61	.0084 / 213
	.0100 / 250	.0150 / 381	.0210 / 533	.0060 / 152	.0060 / 152	.0130 / 330	.0250 / 635	.0040 / 102	.0570 / 1448	.0030 / 76	.0105 / 267
	.0120 / 300	.0180 / 457	.0300 / 762	.0072 / 183	.0072 / 183	.0210 / 533	.0300 / 762	.0060 / 152	.0880 / 2235	.0036 / 91	.0126 / 320
		$\pm .0005/13$	$\pm .0005/13$	$\pm .0005/13$	$\pm .0005/13$	(Ref)	$\pm .0005/13$	(Ref)	$\pm .0010/25$	$\pm .0002/5$	$\pm .0005/13$
1016A 2016A	.0030 / 75	.0045 / 114	.0090 / 229	.0018 / 46	.0018 / 46	.0070 / 178	.0075 / 191	.0040 / 102	.0350 / 889	.0015 / 68	.0033 / 84
	.0040 / 100	.0060 / 152	.0120 / 305	.0024 / 61	.0024 / 61	.0095 / 241	.0100 / 254	.0040 / 102	.0400 / 1016	.0020 / 51	.0044 / 112
	.0050 / 125	.0075 / 191	.0150 / 381	.0030 / 76	.0030 / 76	.0115 / 292	.0125 / 318	.0040 / 102	.0450 / 1143	.0025 / 64	.0055 / 140
	.0060 / 150	.0900 / 229	.0180 / 457	.0036 / 91	.0036 / 91	.0140 / 356	.0150 / 381	.0040 / 102	.0500 / 1270	.0030 / 76	.0066 / 168
	.0070 / 175	.0105 / 267	.0210 / 533	.0042 / 107	.0042 / 107	.0165 / 419	.0175 / 445	.0040 / 102	.0570 / 1448	.0035 / 89	.0077 / 196
	.0080 / 200	.0120 / 305	.0210 / 533	.0048 / 122	.0048 / 122	.0155 / 394	.0200 / 508	.0040 / 102	.0570 / 1448	.0040 / 102	.0088 / 224
	.0100 / 250	.0150 / 381	.0210 / 533	.0060 / 152	.0060 / 152	.0145 / 368	.0250 / 635	.0040 / 102	.0570 / 1448	.0050 / 127	.0110 / 279
	.0120 / 300	.0180 / 457	.0300 / 762	.0072 / 183	.0072 / 183	.0220 / 559	.0300 / 762	.0060 / 152	.0880 / 2235	.0060 / 152	.0132 / 335

INLINE GROOVE NOTCH TOOLS - GENERAL GUIDELINES ON HOW TO ORDER

STYLE		FEED ANGLE
1015A	Inline and "U" Groove	30°
1016A	Inline and 60° "V" Groove	30°
2015A	Inline and "U" Groove	45°
2016A	Inline and 60° "V" Groove	45°
60° wire feed available with slimline		

WIRE SIZE	MATERIAL
Specify Wire Size	W : Tungsten Carbide Ultra Fine Grain for Aluminum Wire

Tool Dia	TD in / mm ±.0001"/3µm	TDF in / mm ±.0005"/13µm	Specified Length	TL in / mm ±.005"/130µm
1/16	.0624 / 1.585	.0570 / 1.448 *	3/4	.750 / 19.05
1/8	.1249 / 3.172	.0937 / 2.378 ***	L	.828 / 21.0
2mm	.0785 / 1.995 @	.0630 / 1.600 *	1.00	1.000 / 25.4
3mm	.1180 / 2.997	.0985 / 2.502 **	30mm	1.181 / 30.0

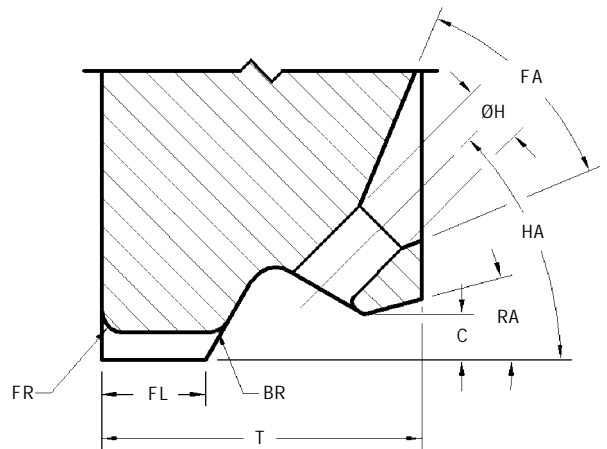
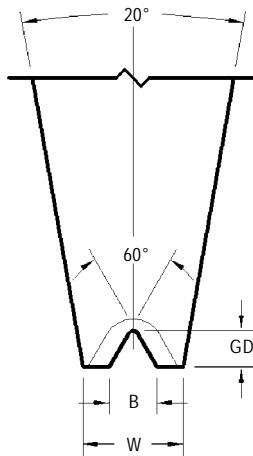
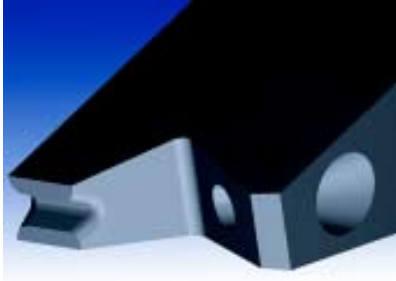
NOTE	
*	limited size availability.
**	.110" / 2.79mm TDF supplied if required by foot geometry.
***	.1180" / 3.00mm TDF supplied if required by foot geometry.
@	Tolerance +0 / - .0002" / 5µm

FOOT OPTIONS	
G	The FR and BR are polished and a fine matte finish is within the area of the groove. (Standard)
GM	The FR, BR and groove have a matte finish

HOW TO ORDER	
SPECIFY	Style - Wire - Material - Tool Diameter - Tool Length - Foot Option (For modifications to standard tools, use part number and specify modified dimensions or contact our technical support staff for assistance with your requirements). For Shank Style refer to page 62.
EXAMPLE	1016A - 5 - W - 3mm - L - GM 1015A - 8 - W - 1/8 - L - G 2015A-10 - W - 3MM - 1.00-G 2016A-12 - W - 1/8-1.00-GM

INLINE GROOVE NOTCH TOOLS

30D6 / 45D6 / 60D6STYLE



30D6 HA = 30°, FA = 45°, RA = 15°
 45D6 HA = 45°, FA = 45°, RA = 15°
 60D6 HA = 60°, FA = 30°, RA = 15°

STANDARD DIMENSIONS

Tool Styles	Wire Size	Useable Wire Diameter WD in / μm	Hole Diameter H in / μm $\pm .0005 / 13$	Foot Length FL in / μm $\pm .0005 / 13$	Front/Back Radius FR = BR in / μm (Ref)	Foot Width W in / μm $\pm .0005 / 13$	Clearance C in / μm (Ref)	30D6 Tip Length T in / μm $\pm .0010 / 25$	45/60D6 Tip Length T in / μm $\pm .0010 / 25$	Groove Depth GD in / μm Min	Groove Opening B in / μm $\pm .0003 / 18$
30D6 45D6 60D6	75	.0030 / 75	.0045 / 114	.0080 / 203	.0015 / 38	.0075 / 191	.0030 / 76	.0350 / 889	.0240 / 610	.0021 / 53	.0033 / 84
	100	.0040 / 100	.0060 / 152	.0105 / 267	.0020 / 51	.0100 / 254	.0030 / 76	.0390 / 991	.0350 / 889	.0028 / 71	.0044 / 112
	125	.0050 / 125	.0075 / 191	.0130 / 330	.0025 / 64	.0120 / 305	.0050 / 127	.0500 / 1270	.0400 / 1016	.0035 / 89	.0055 / 140
	150	.0060 / 150	.0900 / 229	.0155 / 394	.0030 / 76	.0140 / 356	.0050 / 127	.0590 / 1499	.0530 / 1346	.0042 / 107	.0066 / 168
	175	.0070 / 175	.0105 / 267	.0180 / 457	.0035 / 89	.0155 / 394	.0050 / 127	.0700 / 1778	.0560 / 1422	.0049 / 124	.0077 / 196
	200	.0080 / 200	.0120 / 305	.0205 / 521	.0040 / 102	.0175 / 445	.0080 / 203	.0790 / 2007	.0620 / 1575	.0056 / 142	.0088 / 224
			$\pm .0005 / 13$	$\pm .0005 / 13$	(Ref)	$\pm .0005 / 13$	(Ref)	$\pm .0010 / 25$	$\pm .0010 / 25$	Min	$\pm .0005 / 13$
	250	.0100 / 250	.0150 / 381	.0270 / 686	.0050 / 127	.0215 / 546	.0080 / 203	.0900 / 2286	.0790 / 2007	.0070 / 178	.0110 / 279

INLINE GROOVE NOTCH TOOLS - GENERAL GUIDELINES ON HOW TO ORDER

STYLE		FEED ANGLE
30D6	Inline and 60° "V" Groove	30°
45D6		45°
60D6		60°

WIRE SIZE	MATERIAL
Specify Wire Size	W: Tungsten Carbide Ultra Fine Grain for Aluminum Wire

Tool Dia	TD in / mm ±.0001"/3µm	TDF in / mm ±.0005"/13µm	Specified Length	TL in / mm ±.005"/130µm
1/16	.0624 / 1.585	.0570 / 1.448 *	3/4	.750 / 19.05
1/8	.1249 / 3.172	.0937 / 2.378 ***	L	.828 / 21.0
2mm	.0785 / 1.995 @	.0630 / 1.600 *	1.00	1.000 / 25.4
3mm	.1180 / 2.997	.0985 / 2.502 **	30mm	1.181 / 30.0

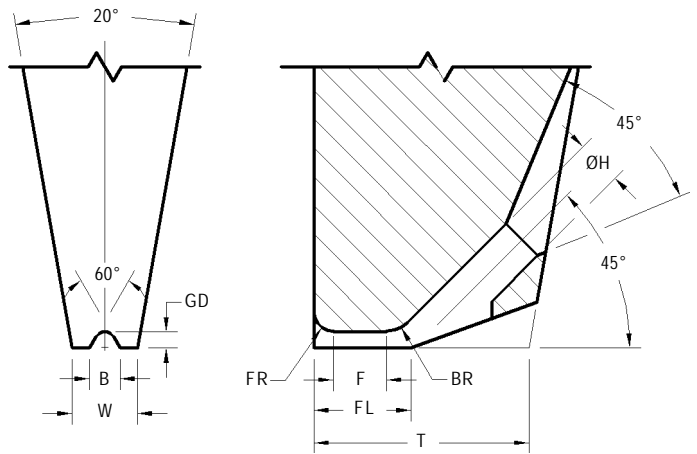
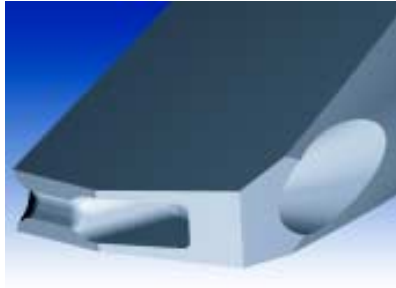
NOTE	
*	limited size availability.
**	.110" / 2.79mm TDF supplied if required by foot geometry.
***	.1180" / 3.00mm TDF supplied if required by foot geometry.
@	Tolerance +0 / - .0002" / 5µm

FOOT OPTIONS	
G	The FR and BR are polished and a fine matte finish is within the area of the groove. (Standard)
GM	The FR, BR and groove have a matte finish

HOW TO ORDER	
SPECIFY	Style - Wire - Material - Tool Diameter - Tool Length - Foot Option (For modifications to standard tools, use part number and specify modified dimensions or contact our technical support staff for assistance with your requirements). For Shank Style refer to page 62.
EXAMPLE	45D6 - 250 - W - 1/8 - 1.00 - G 30D6 - 150 - W - 3mm - 30mm - G 60D6 - 200 - W - 1/8 - 1.00 - GM

INLINE GROOVE AUTOBONDING TOOLS

AB16 STYLE



STANDARD DIMENSIONS

Tool Styles - Wire Size / Foot Size	Useable Wire Diameter WD in / μm	Hole Diameter H in / μm $\pm .0005/13$	Foot Length FL in / μm $\pm .0005/13$	Front Radius FR in / μm $\pm .0005/13$	Back Radius BR in / μm $\pm .0005/13$	Flat F in / μm (Ref)	Foot Width W in / μm $\pm .0005/13$	Tip Length T in / μm $\pm .0010/25$	Groove Depth GD in / μm $\pm .0002/5$	Groove Opening B in / μm $\pm .0005/13$
AB16-3XS	.0030 / 75	.0055 / 140	.0039 / 99	.0024 / 61	.0036 / 91	.0015 / 38	.0075 / 191	.0220 / 559	.0015 / 38	.0033 / 84
AB16-3S	.0030 / 75	.0055 / 140	.0049 / 124	.0024 / 61	.0036 / 91	.0025 / 64	.0075 / 191	.0230 / 584	.0015 / 38	.0033 / 84
AB16-3R	.0030 / 75	.0055 / 140	.0059 / 150	.0024 / 61	.0036 / 91	.0035 / 89	.0075 / 191	.0240 / 610	.0015 / 38	.0033 / 84
AB16-3L	.0030 / 75	.0055 / 140	.0069 / 175	.0024 / 61	.0036 / 91	.0045 / 114	.0075 / 191	.0250 / 635	.0015 / 38	.0033 / 84
AB16-4S	.0040 / 100	.0070 / 178	.0064 / 163	.0032 / 81	.0048 / 122	.0030 / 76	.0100 / 254	.0300 / 762	.0020 / 51	.0044 / 112
AB16-4R	.0040 / 100	.0070 / 178	.0084 / 213	.0032 / 81	.0048 / 122	.0050 / 127	.0100 / 254	.0320 / 813	.0020 / 51	.0044 / 112
AB16-4L	.0040 / 100	.0070 / 178	.0094 / 239	.0032 / 81	.0048 / 122	.0060 / 152	.0100 / 254	.0330 / 838	.0020 / 51	.0044 / 112
AB16-5S	.0050 / 125	.0090 / 229	.0080 / 203	.0040 / 102	.0060 / 152	.0040 / 102	.0125 / 318	.0380 / 965	.0025 / 64	.0055 / 140
AB16-5R	.0050 / 125	.0090 / 229	.0100 / 254	.0040 / 102	.0060 / 152	.0060 / 152	.0125 / 318	.0400 / 1016	.0025 / 64	.0055 / 140
AB16-5L	.0050 / 125	.0090 / 229	.0115 / 292	.0040 / 102	.0060 / 152	.0075 / 191	.0125 / 318	.0410 / 1041	.0025 / 64	.0055 / 140
AB16-8S	.0080 / 200	.0145 / 368	.0130 / 330	.0064 / 163	.0096 / 244	.0065 / 165	.0200 / 508	.0610 / 1549	.0040 / 102	.0088 / 224
AB16-8R	.0080 / 200	.0145 / 368	.0160 / 406	.0064 / 163	.0096 / 244	.0095 / 241	.0200 / 508	.0640 / 1626	.0040 / 102	.0088 / 224
AB16-8L	.0080 / 200	.0145 / 368	.0185 / 470	.0064 / 163	.0096 / 244	.0120 / 305	.0200 / 508	.0670 / 1702	.0040 / 102	.0088 / 224
		$\pm .0005/13$	$\pm .0005/13$	$\pm .0010/25$	$\pm .0010/25$	(Ref)	$\pm .0010/25$	$\pm .0010/25$	$\pm .0003/8$	$\pm .0006/15$
AB16-10S	.0100 / 250	.0180 / 457	.0160 / 406	.0080 / 203	.0120 / 305	.0080 / 203	.0080 / 203	.0760 / 1930	.0050 / 127	.0110 / 279
AB16-10R	.0100 / 250	.0180 / 457	.0200 / 508	.0080 / 203	.0120 / 305	.0120 / 305	.0120 / 305	.0800 / 2032	.0050 / 127	.0110 / 279
AB16-10L	.0100 / 250	.0180 / 457	.0230 / 584	.0080 / 203	.0120 / 305	.0150 / 381	.0150 / 381	.0830 / 2108	.0050 / 127	.0110 / 279

INLINE GROOVE AUTOBONDING TOOLS - GENERAL GUIDELINES ON HOW TO ORDER

STYLE		FEED ANGLE
AB16	Inline and 60° "V" Groove	45° 60° wire feed available with slimline

WIRE SIZE	MATERIAL
Specify Wire Size	W : Tungsten Carbide Ultra Fine Grain for Aluminum Wire

Tool Dia	TD in / mm ±.0001"/3µm	TDF in / mm ±.0005"/13µm	Specified Length	TL in / mm ±.005"/130µm
1/16	.0624 / 1.585	.0570 / 1.448 *	3/4	.750 / 19.05
1/8	.1249 / 3.172	.0937 / 2.378 ***	L	.828 / 21.0
2mm	.0785 / 1.995 @	.0630 / 1.600 *	1.00	1.000 / 25.4
3mm	.1180 / 2.997	.0985 / 2.502 **	30mm	1.181 / 30.0

NOTE	
*	limited size availability.
**	.110" / 2.79mm TDF supplied if required by foot geometry.
***	.1180" / 3.00mm TDF supplied if required by foot geometry.
@	Tolerance +0 / - .0002" / 5µm

FOOT OPTIONS	
G	The FR and BR are polished and a fine matte finish is within the area of the groove. (Standard)
GM	The FR, BR and groove have a matte finish

HOW TO ORDER	
SPECIFY	Style - Wire / Foot Size - Material - Tool Diameter - Tool Length - Foot Option (For modifications to standard tools, use part number and specify modified dimensions or contact our technical support staff for assistance with your requirements). For Shank Style refer to page 62.
EXAMPLE	AB16 - 5R - W - 3mm - L - GM AB16 - 8L - W - 1/8 - L - G

SINGLE POINT-TAB BONDING TOOLS

Nearly every desktop computer and server in use today contains one or more hard-disk drives. Every mainframe and supercomputer is normally connected to hundreds of them. You can even find VCR-type devices, portable music players such as MP3 devices, and camcorders that use Hard disks instead of tape. These billions of hard disks do one thing well-they store changing digital information in a relatively permanent form. They give computers the ability to remember things when the power goes out.

Advancement in Technology has lead to the increase in the storage capacity of the hard disk drive. The evolution towards a smaller slider has challenged the head-gimbal assembly (HGA), and head stack assembly (HSA) processes for new bonding techniques.

Flexible traces are rapidly replacing wires in the disk drive industry. These traces can be bonded with various tip designs. These bonding tools have been develop by SPT, by using a new innovative molding process to ensure tip to tip repeatability.

The most common tip configuration is the waffle tip design when using molded ceramic material. The groove or protruding (+) or (X) design when using polycrystalline diamond (PCD) tip.

Advantage of using the waffle tool design is for maximizing the transfer of ultrasonic energy during bonding where optimum bonding conditions are not present. In addition, the tool is designed with a 4-sided radius edges for orientation Flexibility. The Shank can be designed to fit wedge or Capillary transducers.

SINGLE POINT-TAB BONDING TOOLS



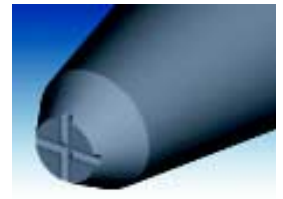
SQUARE WAFFLE FOOT



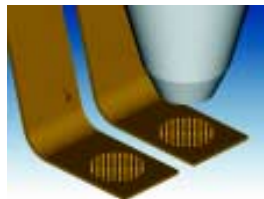
ROUND WAFFLE FOOT



**DOUBLE CROSS
GROOVE 7000 STYLE**



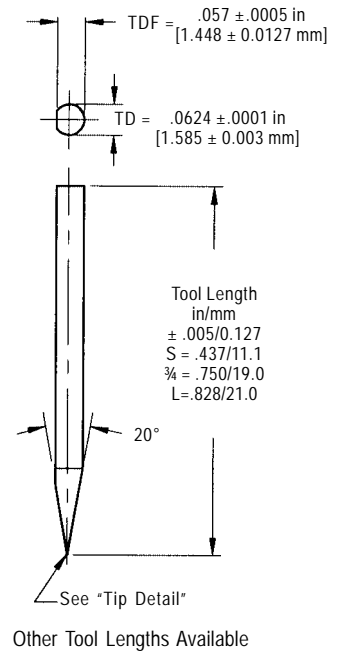
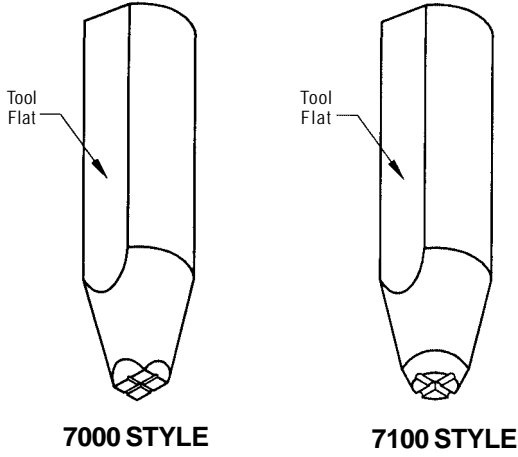
**DOUBLE CROSS
GROOVE 7100 STYLE**



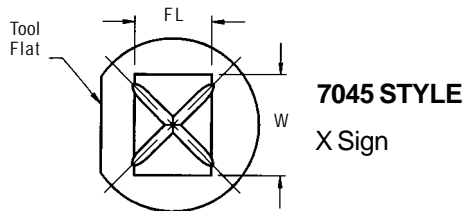
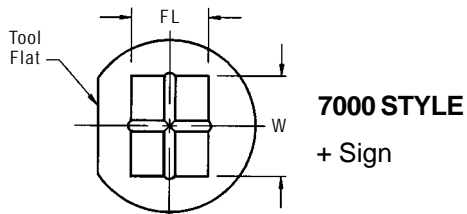
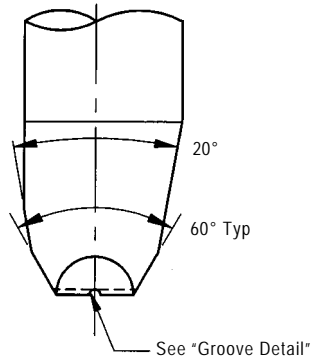
WIRE IMPRESSION

DOUBLE CROSS GROOVE SINGLE POINT-TAB TOOL

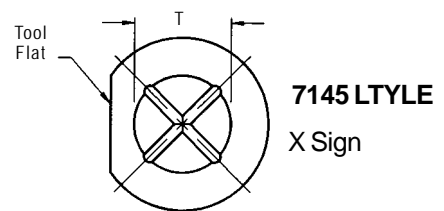
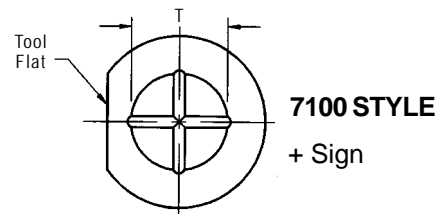
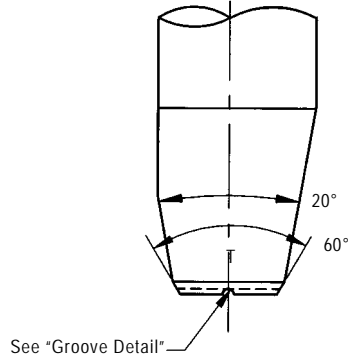
7000 / 7100 STYLES



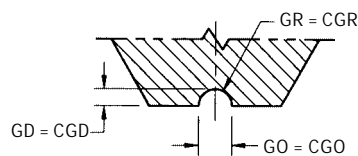
TIP DETAIL



TIP DETAIL



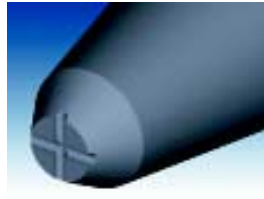
GROOVE DETAIL



DOUBLE CROSS GROOVE SINGLE POINT-TAB TOOLS - GENERAL GUIDELINES ON HOW TO ORDER



**DOUBLE CROSS
GROOVE 7000 STYLE**



**DOUBLE CROSS
GROOVE 7100 STYLE**

STYLE		MATERIAL	
7000 / 7100 7045 / 7145	Double Cross Groove	AZO*	Molded Ceramic (for high volume)
		DT	Diamond Tip
		C	Cermet composite for Gold Wire (recommended for Low Temperature bonding)
		TI	Titanium Carbide Composite for Gold Wire

TIP DETAILS		FOOT OPTIONS	
W/FL	Specify "W" and "FL"	M	Matte Finish
T	Specify "T"		

HOW TO ORDER	
SPECIFY	Style/Groove Set - Material - W/FL or T - Tool Length - Foot Option
EXAMPLE	7000A- AZO - 4025 - S - M 7145B - DT- 0050 - .375- M 7045B - TI - 8060 - ¼- M

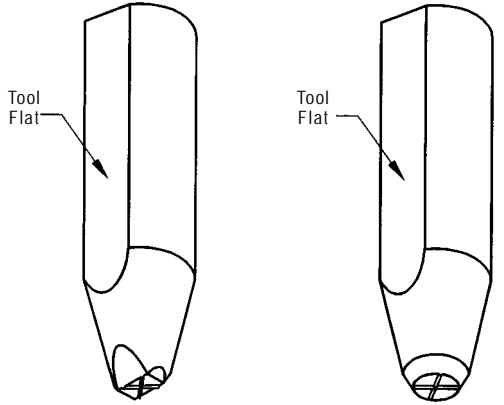
STANDARD GROOVE DIMENSIONS			
Groove Set	GO = CGO in / μm $\pm .0002/5$	GD = CGD in / μm $\pm .0001/3$	GR = CGR in / μm (Ref)
A	.0010 / 25	.0005 / 13	.0005 / 13
B	.0015 / 38	.0008 / 20	.0008 / 20

Include Groove Set call out after Tool Style name to indicate which groove dimensions are desired.

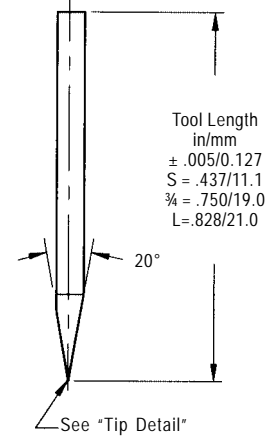
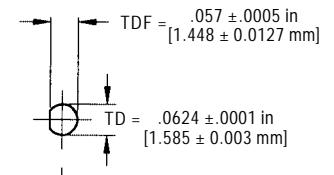
STANDARD DIMENSIONS				
7000, 7045 Tool Style			7100, 7145 Tool Style	
W/FL	Foot Width W in / μm $\pm .0002/5$	Foot Length FL in / μm $\pm .0002/5$	T	Tip Diameter T in / μm $\pm .0002/5$
4025	.0040 / 102	.0025 / 64	0030	.0030 / 76
4030	.0040 / 102	.0030 / 76	0035	.0035 / 89
4035	.0040 / 102	.0035 / 89	0040	.0040 / 102
4040	.0040 / 102	.0040 / 102	0045	.0045 / 114
5030	.0050 / 125	.0030 / 76	0050	.0050 / 125
5035	.0050 / 125	.0035 / 89	0055	.0055 / 140
5040	.0050 / 125	.0040 / 102	0060	.0060 / 152
5045	.0050 / 125	.0045 / 114	0070	.0070 / 178
5050	.0050 / 125	.0050 / 125		
5055	.0050 / 125	.0055 / 140		
6045	.0060 / 152	.0045 / 114		
6050	.0060 / 152	.0050 / 125		

DOUBLE CROSS PROTRUSION SINGLE POINT-TAB TOOL

7500 / 7600 STYLES

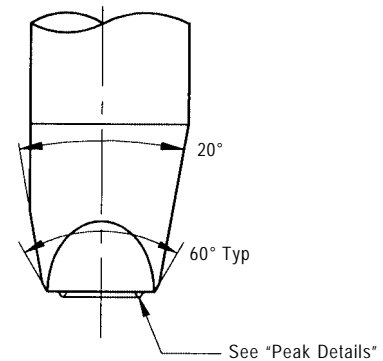


7500 STYLE 7600 STYLE

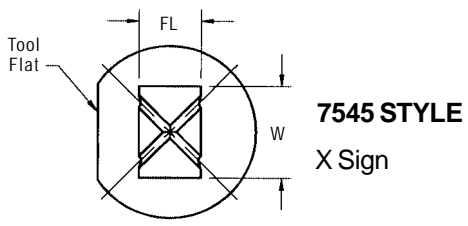
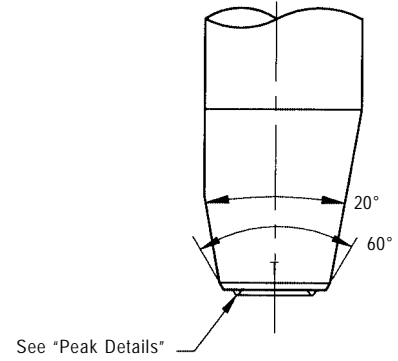


Other Tool Lengths Available

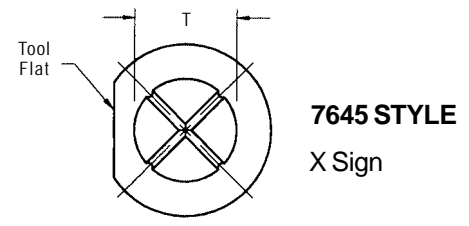
TIP DETAIL



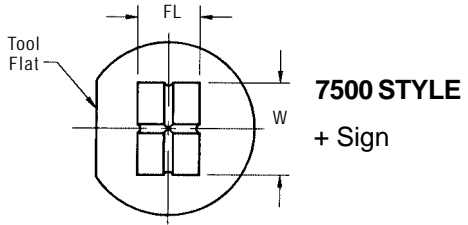
TIP DETAIL



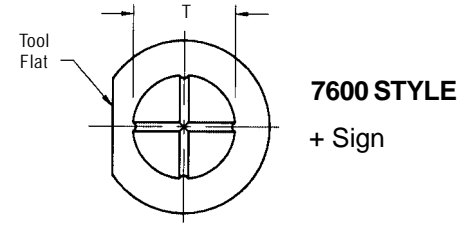
7545 STYLE
X Sign



7645 STYLE
X Sign

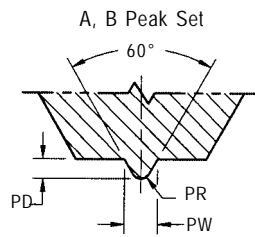


7500 STYLE
+ Sign

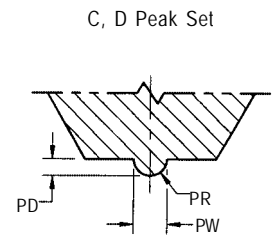


7600 STYLE
+ Sign

Peak DETAIL



A, B Peak Set



C, D Peak Set

DOUBLE CROSS PROTRUSION SINGLE POINT-TAB TOOLS - GENERAL GUIDELINES ON HOW TO ORDER



DOUBLE CROSS PROTRUSION 7500/7600"

STYLE		MATERIAL	
7500 / 7600 7545 / 7645	Double Cross Protrusion	AZO*	Molded Ceramic (for high volume)
		DT	Diamond Tip
		C	Cermet composite for Gold Wire (recommended for Low Temperature bonding)
		TI	Titanium Carbide Composite for Gold Wire

TIP DETAILS		FOOT OPTIONS	
W/FL	Specify "W" and "FL"	M	Matte Finish
T	Specify "T"		

HOW TO ORDER	
SPECIFY	Style/Peak Set - Material - W/FL or T - Tool Length - Foot Option
EXAMPLE	7500A - AZO - 4025 - S - M 7545B - DT - 8060 - .375 - M 7645B - TI - 0060 - 3/4 - M

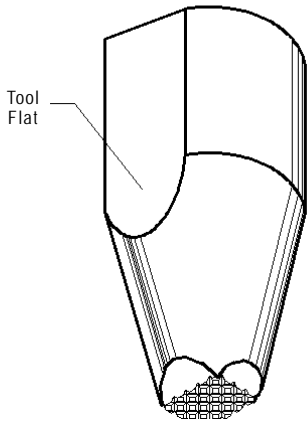
STANDARD PEAK DIMENSIONS				
Peak Set	Peak Shape	PW in / μm $\pm .0002/5$	PD in / μm $\pm .0001/3$	PR in / μm (Ref)
A	60° V	.0005 / 13	.0025 / 6	.0002 / 5
B	60° V	.0008 / 20	.0005 / 13	.0002 / 5
C	Radius	.0006 / 15	.0003 / 8	.0003 / 8
D	Radius	.0010 / 25	.0005 / 13	.0005 / 13

Include Peak Set call out after Tool Style name to indicate Groove dimensions.

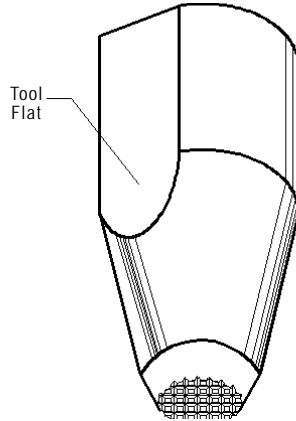
STANDARD DIMENSIONS				
7500, 7545 Tool Style			7600, 7645 Tool Style	
W/FL	Foot Width W in / μm $\pm .0002/5$	Foot Length FL in / μm $\pm .0002/5$	T	Tip Diameter T in / μm $\pm .0002/5$
4035	.0040 / 102	.0035 / 89	0030	.0030 / 76
4040	.0040 / 102	.0040 / 102	0035	.0035 / 89
6035	.0060 / 152	.0035 / 89	0040	.0040 / 102
6040	.0060 / 152	.0040 / 102	0050	.0050 / 125
6050	.0060 / 152	.0050 / 125	0055	.0055 / 140
6060	.0060 / 152	.0060 / 152	0060	.0060 / 152
			0070	.0070 / 178
8040	.0080 / 203	.0040 / 102		
8050	.0080 / 203	.0050 / 125		
8060	.0080 / 203	.0060 / 152		
8070	.0080 / 203	.0070 / 178		

WAFFLE FOOT SINGLE POINT-TAB TOOLS

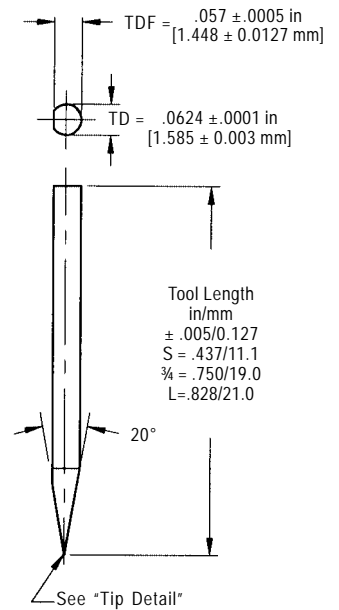
7045W / 7145W STYLES



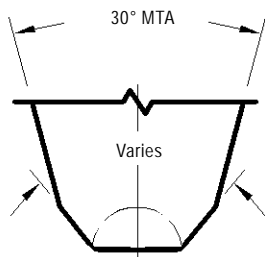
7045W STYLE



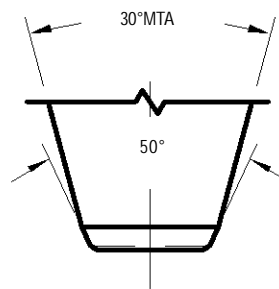
7145W STYLE



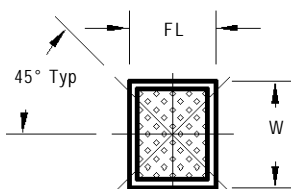
Other Tool Lengths Available



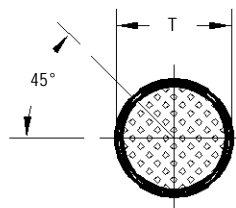
7045W STYLE



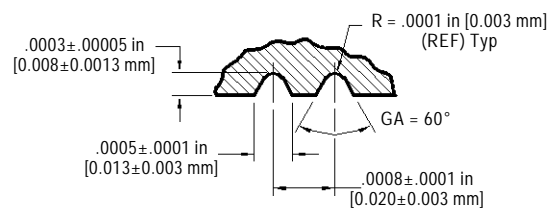
7145W STYLE



7045W STYLE



7145W STYLE



TYPICAL GROOVE DETAIL

WAFFLE FOOT SINGLE POINT-TAB TOOLS - GENERAL GUIDELINES ON HOW TO ORDER



**SQUARE WAFFLE FOOT
7045W STYLE**



**ROUND WAFFLE FOOT
7145W STYLE**

STYLE		MATERIAL	
7045W / 7145W	Waffle Tip	AZO* DT C	Molded Ceramic (for high volume) Diamond Tip Cermet composite for Gold Wire (recommended for Low Temperature bonding)

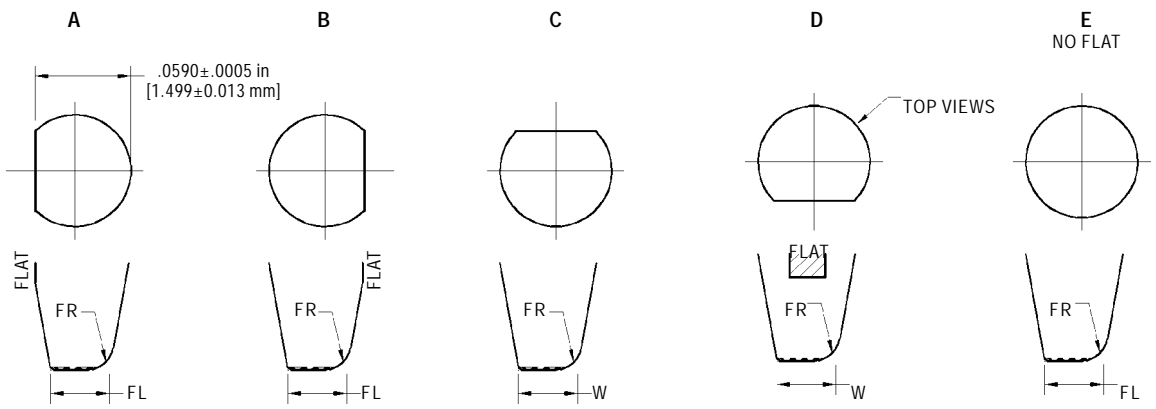
TIP DETAILS		FOOT OPTIONS	
W/FL T	Specify "W" and "FL" Specify "T"	M	Matte Finish

HOW TO ORDER	
SPECIFY	Style - Material - W/FL or T - Tool Length - Foot Finish - Flat Orientation
EXAMPLE	7145W - AZO - 0050 - .375 - M - (Reference Page 60) 7045W - DT- 8070 - ¼- M - (Reference Page 60)

STANDARD DIMENSIONS						
7045 Tool Style				7145 Tool Style		
W/FL	Foot Width W in / μm $\pm .0002/5$	Foot Length FL in / μm $\pm .0002/5$	Shank Style	T	Tip Diameter T in / μm $\pm .0002/5$	Flat Orientation
5055	.0050 / 127	.0055 / 140	See Page 60	0050*	.0050 / 125	See Chart
6949	.0069 / 175	.0049 / 124	See Page 60	0055	.0055 / 140	See Chart
7080	.0070 / 178	.0080 / 203	See Page 60	0060	.0060 / 152	See Chart
7360	.0073 / 185	.0060 / 152	See Page 60	0070	.0070 / 178	See Chart
7474	.0074 / 188	.0074 / 188	See Page 60	0075	.0075 / 191	See Chart
8070	.0080 / 203	.0070 / 178	See Page 60			
8090	.0080 / 203	.0090 / 229	See Page 60			
9060	.0090 / 229	.0060 / 152	See Page 60			

WAFFLE FOOT SINGLE POINT-TAB TOOLS

7045W WAFFLE TIP



7045W WAFFLE SHANK FLATS

SINGLE POINT TAB
BONDING TOOLS

SMALL WIRE SHANK STYLE

VERTICAL HOLE SHANK - V STYLE, J STYLE, H STYLE, P STYLE

Some wedge bonders position the wire clamp mechanisms above the tool in order to accommodate deep access or tight clearance packages. By moving the clamps above the tool, you can bond closer to the sides of the package or other devices.

The tool itself has a hole running down the center, exiting above the wire feed hole. The angle of the wire feed is usually 45deg or 55deg, in order to minimize the bending of the wire.

Note : For Delvotec bonders, specify VBL = 060

How To Order: The vertical hole shank style can be ordered by modifying the beginning of the style field in the part number format. Use the letter 'V' to begin the part numbers when you need a vertical hole tool.

Tool Style	Tool Style with vertical hole
UT	VU
FP	VF
COB	VC
M	VM
RW	VR
ABT	VA

SPECIAL CLEARANCE FOR VERTICAL HOLE SHANK - J STYLE

Special Clearance with vertical hole shank is commonly used where deep access is required during bonding to the IC. The double relief allows for maximum clearance of the package while containing the wire in the vertical hole, preventing it to contact the package walls. This prevents wire damage and wire drag which can cause poor looping performance.

How To Order: The vertical hole shank style can be ordered by modifying the beginning of the style field in the part number format. Use the letter 'J' to begin the part numbers when you need a vertical hole tool.

Tool Style	Tool Style with vertical hole (special clearance)
UT	JU
FP	JF
COB	JC
M	JM
RW	JR
ABT	JA

DOUBLE FLAT SHANK - H STYLE

Another deep access shank configuration is the double flat shank. The wire is fed from the top of the tool, in between the tool and the transducer, down to the wire feed hole. A clamp presses the wire against the back side of the tool. The wire feed angles are usually 45deg or 55deg.

How To Order: The double flat shank style can be ordered by modifying the beginning of the style field in the part number format. Use the letter 'H' to begin the part numbers when you need a double flat tool.

Tool Style	Tool Style with vertical hole
UT	HU
FP	HF
COB	HC
M	HM
RW	HR
ABT	HA

DOUBLE FLAT SHANK, ENHANCED TRANSDUCER CONTACT - P STYLE

A design enhancement of the double flat shank puts a full diameter at the top of the tool where it is mounted to the transducer. This increased tool to transducer contact transmits the ultrasonic energy more efficiently down the tool.

How To Order: The enhanced transducer contact design can be ordered by modifying the beginning of the style field in the part number format. Use the letter 'P' to begin the part numbers when you need a double flat tool.

Tool Style	Tool Style with vertical hole
UT	PU
FP	PF
COB	PC
M	PM
RW	PR
ABT	PA

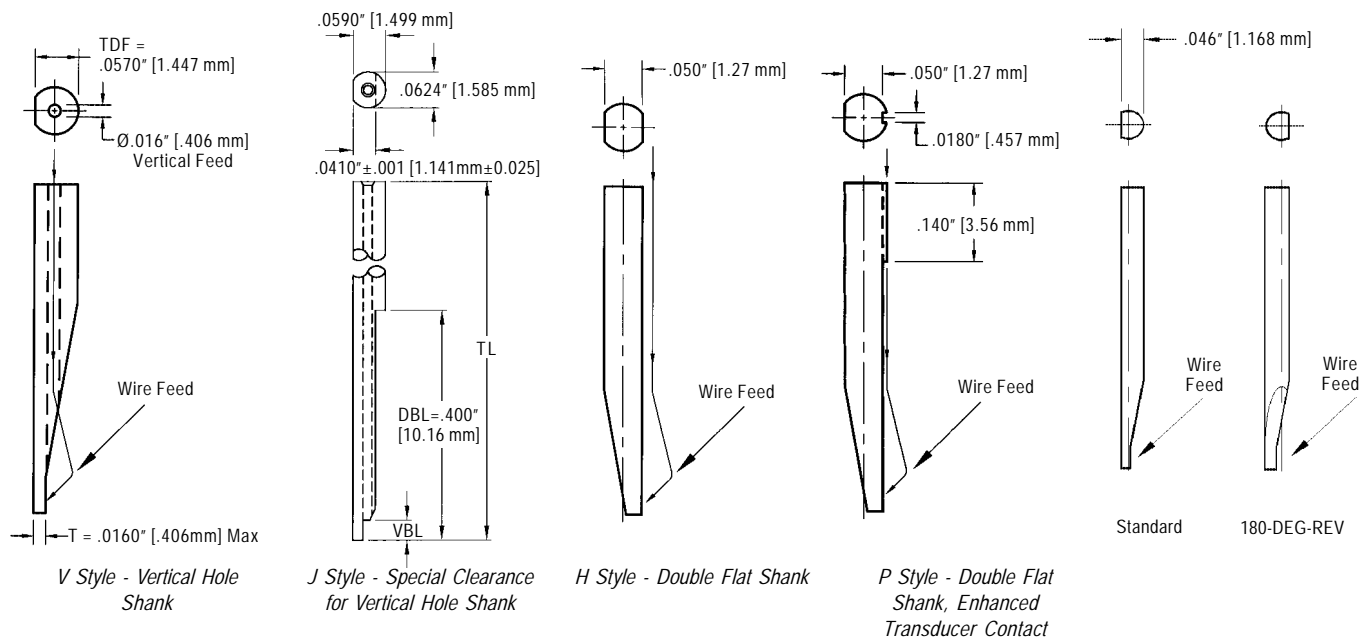
180-DEG-REV SHANK

This shank design feeds the wire from the flat side of the tool. Specify '180-DEG-REV' at the end of the part number.

For DIAS wedge bonders and K&S 8060.

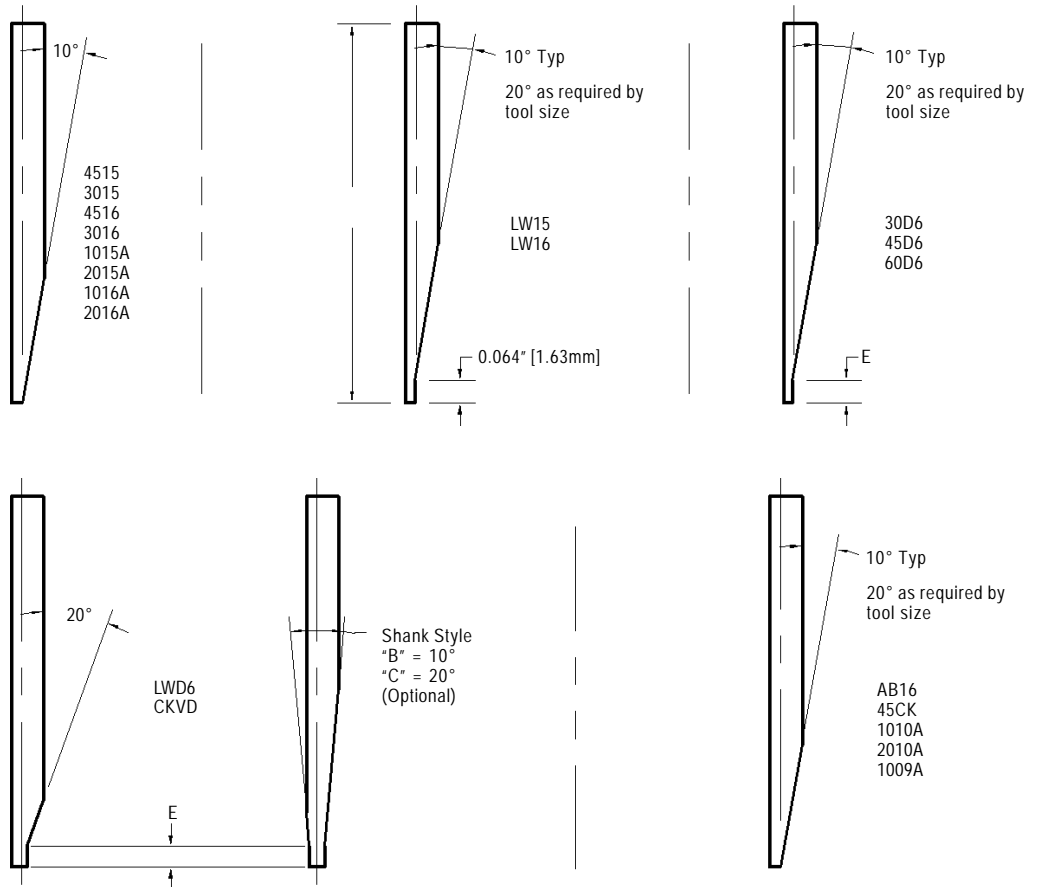
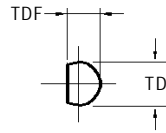
Max Ribbon Width .010"

EXAMPLE : FP30A - W - 2520 - .540 - CM
180 - DEG - REV



SMALL / LARGE WIRE SHANK STYLES

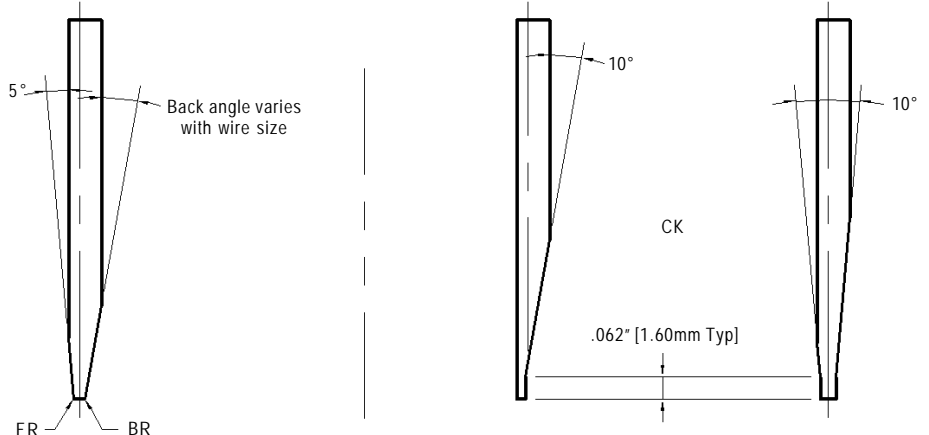
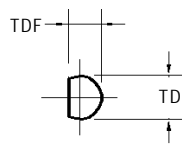
LARGE WIRE SHANK STYLES



Shank Style A

Shank Style B
in 2mm only

Shank Style A used unless specified at end of a part number



OSG7

Shank Style A
(Standard)

Shank Style B
(Optional)
in 2mm only

Shank Style A used unless specified at end of a part number

TIP TO SHANK RATIOS

TIP TO SHANK RATIOS

When selecting a wedge,

- * The amplitude of the tools vibration at its foot is a ratio of the input (shank) diameter to the output (foot) diameter..
- * Bonding wedges are designed with varying tip-to-shank dimensional ratios.
- * The smaller the tip the higher the amplitude which will rapidly dampen in contact with the bond surface.
- * As the tip grows with the same input amplitude, will vibrate at a comparatively lower amplitude but dampens more slowly, presenting the hazards of over-working the bond.
- * In general, larger wire requires more energy to bond than small wire.
- * Stiffer wedges works best as wire size increases.



TOOL SELECTION GUIDE

Company	Model #	Manual	Semi	Auto	Wire Dia.	Wire		Ribbon Size	SPT Tool	Shank Style	Feed Angle					TL	TD	TDF	
						Au	Al				30°	38°	45°	55°	60°				
West Bond	7400E	X			.0007-.002	X	X		M	Std,			X	X		¾, L	1/16		
	7400D	X			.0007-.002	X	X		M, VM	Std, V, J			X	X		¾, L	1/16		
	7476E	X			.0007-.002	X	X		M	Std			X	X		¾, L	1/16		
	747630E	X			.0007-.002	X	X	.0005 x .010	M,VM, RW, VR	STD, V, J			X	X		¾, L	1/16		
	747677E	X			.0007-.002	X	X		M, VM	Std, V, J			X	X		¾, L	1/16		
	747730E	X			.0007-.002	X	X	.0005 x .010	M,VM, RW, VR	Std, V, J			X	X		¾, L	1/16		
	4546E			X		.0007-.002	X	X		FP, VF	Std, V, J			X	X		¾, L	1/16	
	454630E			X		.0007-.002	X	X		FP, VF	Std, V, J			X	X		¾, L	1/16	
	454647E			X		.0007-.002	X	X		FP, VF	Std, V, J			X	X		¾, L	1/16	
	454730E			X		.0007-.002	X	X		FP, VF	Std, V, J			X	X		¾, L	1/16	
	5456E			X		.0007-.002	X	X		FP, VF	Std, V, J			X	X		¾, L	1/16	
	545630E			X		.0007-.002	X	X		FP, VF	Std, V, J			X	X		¾, L	1/16	
	545657E			X		.0007-.002	X	X		FP, VF	Std, V, J			X	X		¾, L	1/16	
	545730E			X		.0007-.002	X	X		FP, VF	Std, V, J			X	X		¾, L	1/16	
	2400B				X	.0007-.002	X	X		FP	Std			X	X		¾, L	1/16	
	2600B				X	.0007-.002	X	X		VF	Std, V, J			X	X		¾, L	1/16	
	2426B				X	.0007-.002	X	X		FP, VF	Std, V, J			X	X		¾, L	1/16	
242627B				X	.0007-.002	X	X		FP, VF	Std, V, J			X	X		¾, L	1/16		
F&k Delvotek	6600 HS			X	.004-.020		X		CKVD, OSG7							2"	1/8		
	6400 DA			X	.0007-.003	X	X	.00125 x .010	FP, VF, RW,VR		X		X	X		¾, 1"	1/16		
	6400			X	.0007-.003	X	X									¾, 1"	1/16		
	5450		X		.004-.020		X		CKVD, OSG7							2"	1/8		
	5432		X		.0007-.003	X	X	.0125 x .008	VF, VR				X			¾, 1"	1/16		
	5430		X		.0007-.003	X	X		M, FP	Std			X		X	¾, 1"	1/16		
HYBOND	M 676		X		.0005-.003	X	X	.001 x .020	M	M,	X		X	X	X	S, ¾	1/16		
	M 572A		X		.0005-.003	X	X	.001 x .020	M, VM	VM, VR			X	X	X	S, ¾	1/16		
	M 572A-40		X		.0005-.003	X	X	.001 x .020	M	VM, VR			X	X	X	.625, ¾	1/16		

TOOL SELECTION GUIDE

Company	Model #	Manual	Semi	Auto	Wire Dia.	Wire		Ribbon Size	SPT Tool	Shank Style	Feed Angle					TL	TD	TDF
						Au	Al				30°	38°	45°	55°	60°			
K & S	484	X			.0007-.003	X	X	.0005 X .020	M, 1001, GW30, 1100, 1010, 1200, 1002, RW	Std, V	X		X		X	S, 3/4, L,	1/16	.046
	486	X			.003 - .010		X		1015	Special	X					S, 3/4, L, Special	Spcl	Spcl
	4123	X			.0007 - .003	X	X	.0005 X .020	ABT, UT, US, M, 1001, 1100, 1200, 1002, GW30, RW	Std, V	X	X	X		X	S, 3/4, L, 1.078	1/16	.046
	4127	X			.003 - .020		X		2015A	Std.			X			S, 3/4, L, Special	1/8	.1180
	4129			X	.0007 - .001	X	X		VF, VU	V					X	3/4, L, 1.078	1/16	.046
	1470			X	.001 - .002	X	X		ABT, US, UT,	Std		X	X			3/4, L, 1.078	1/16	.046
	1471			X	.001 - .002	X	X		ABT, US, UT,	Std		X	X		X	3/4, L, 1.078	1/16	.046
	1474			X	.001 - .002	X	X		FP, UT, ABT,			X	X		X	3/4, L, 1.078	1/16	.046
	1477			X	.004 - .020		X		60D6	Std					X	1.060", 2.00", Special	1/16	.046
	1478			X	.0007 - .002	X	X		ABT, US, UT,	Std		X	X		X	3/4, L, 1.078	1/16	.046
	8060			X	.0008 - .002	X	X		FP	180° Rev.			X		X	L	1/16	.046
	8090			X	.0008 - .002	X	X		FP	180° Rev.			X		X	L	1/16	.046
	TRITON			X	.0008 - .002	X	X		FP	180° Rev.			X		X	L	1/16	.046

TOOL SELECTION GUIDE

Company	Model #	Manual	Semi	Auto	Wire Dia.	Wire		Ribbon Size	SPT Tool	Shank Style	Feed Angle					TL	TD	TDF
						Au	Al				30°	38°	45°	55°	60°			
Orthodyne	M3600			X	.004 - .020		X		OSG7	Std.					64mm	1/8	110	
	M3700			X	.001 - .003	X	X		UT, 4516, AB16	Std.					1.225	1/16	.046	
	M7200			X	.001 - .003 .004 - .020	X	X		UT, 4516, AB16, OSG7	Std.			X		1.225 64mm	1/16 1/8	.046 110	
	M360C			X	.004 - .020		X			Std.					64mm	1/8	110	
	M20			X	.004 - .020	X	X	.0005 X .020	RW, OSG7	Std.			X		1.225 64mm	1/8	110	
	M360S			X	.0015 - .003	X	X		UT, 4516, AB16	Std.			X		1.225	1/16	.046	
	M360C-H			X	.004 - .020	X	X		OSG7	Std.					64mm	1/8	110	
	M360C-HD			X	.004 - .020		X		OSG7	Std.					64mm	1/8	110	
PALOMAR	2470-V			X	.0007 - .003		X	.0005 - .012	HF, HR, PF, PR	Double flat			X	X	3/4, L	1/16	.046	
	3470-II			X	.0007 - .003	X	X	.0005 - .012	HF, HR, PF, PR	Double flat			X	X	3/4, L	1/16	.046	
	5070			X	.0007 - .003	X	X	.0005 - .012	HF, HR, PF, PR	Double flat			X	X	3/4, L	1/16	.046	
ASM	ASM 520			X	.0007-.002	X	X		COB	Std.	X				S, 3/4, L	1/16	.046	
	ASM 559			X	.0007-.002	X	X		COB	Std.	X				S, 3/4, L	1/16	.046	
	ASM 509			X	.0007-.002	X	X		COB	Std	X				S, 3/4, L	1/16	.046	
MEI	M 990					X	X		VF	Std, V			X	X	S, 3/4, L	1/16	.059	
CHO - OMPA	-			X	.004 - .020		X			CK, CKVD								
	-			X	.004 - .012		X		45CK				X					
H & K	M 990BONDJET BJ7xx / 8xx			X	.0007 - .0034	X	X	X	FP, HF, 4516, RW	Std, V, H			X		X	1.00	1/16	.059
	BONDJET BJ9xx			X	.004 - .020		X		CKVD	Style A					1.0, 2.5, 2.68	1/8	110	

SPT Roth Ltd

Fax : ++ 41 32 387 80 88

Small Precision Tools Inc

Fax : 1 707 778 2271

SPT Asia Pte Ltd

Fax : 65 6250 2725

**Small Precision Tools
(Phil) Corp**

Fax : 632 531-5780

**Small Precision Tools
Co Ltd**

Fax : 86 510 516 5233

SPT Japan K.K.

Fax : +81 45 470 6755

Customer : _____ Date : ____ / ____ / ____

Department : _____ Contact No : _____ Extn : _____

Company : _____ Order taken by : _____

ULTRASONIC Bonding WEDGES Requirement Checklist

Application : _____

Lead Count : _____

Wire Diameter : _____ Material : _____

Bonder / Model : _____

Bond Pad Size : _____

Pad Pitch : _____

Loop Height (target) : _____

Deformed Bond Width : _____

Bond Pad Metallization : _____

Distance between Pad to Lead : _____

Lead Width : _____

Lead Pitch : _____

Lead Metallization : _____

Bonding Temperature : _____

Ultrasonic Bonding Frequency : _____

Present Wedge Part Number(s) : _____

Wire Bonding Top 3 Defects : _____

Any Other Wire Bonding problems? _____

Recommended SPT Wedge Part No: _____

SPT Roth Ltd

Werkstrasse 28, CH-3250 Lyss, Switzerland

Tel : ++ 41 32 387 80 80

Fax : ++ 41 32 387 80 88

E-Mail : info@sptroth.com

Small Precision Tools Inc

1330 Clegg Street, Petaluma, CA 94954, USA

Tel : 1 707 765 4545

Fax : 1 707 778 2271

E-Mail : info@sptca.com

SPT Asia Pte Ltd

970 Toa Payoh North, #07-25/26, Singapore 318992

Tel : 65 6253 5577

Fax : 65 6250 2725

E-Mail : info@sptasia.com

Small Precision Tools (Phil) Corp

35 Libertad Street, Mandaluyong City 1550, Philippines

Tel : 632 533-7067

Fax : 632 531-5780

E-Mail : sales@sptphil.com

Small Precision Tools Co Ltd

A2 Building, Liyuan Economic Development Zone,
Wuxi, Jiangsu, P.R.China 214072

Tel : 86 510 516 1968

Fax : 86 510 516 5233

E-Mail : info@sptchina.com

SPT Japan K.K.

9th floor, Shin-Yokohama U.U Building,
2-5-2, Shin-Yokohama, Kohoku-ku,
Yokohama-shi, Kanagawa, 222-0033 Japan

Tel: +81 45 470 6288

Fax: +81 45 470 6755

E-Mail: info@sptjapan.com

