

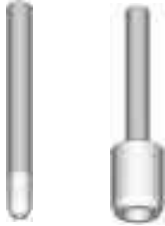

























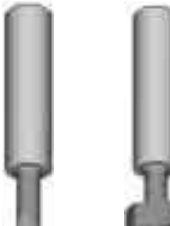











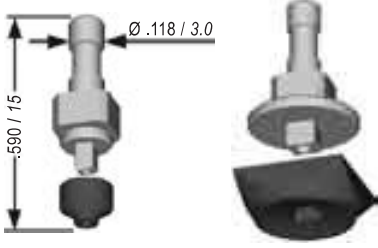



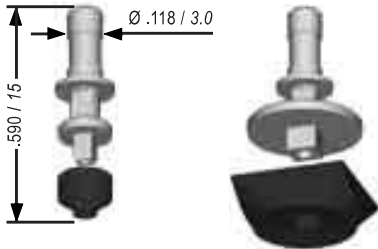



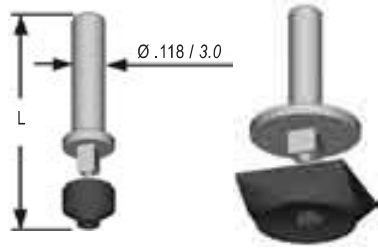



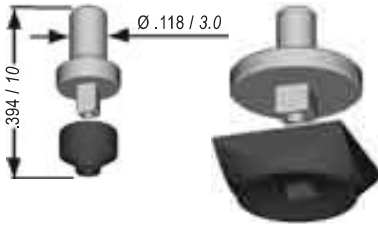

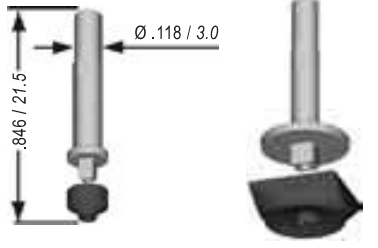



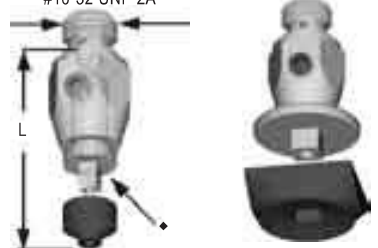





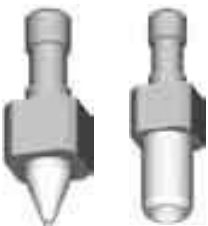









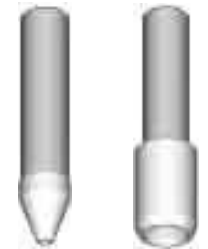









SHANK STYLES USED ON COMMON DIE ATTACH BONDERS

SHANK STYLE	SPECIFY L (inch/mm)	PCTR / FCTR / (H)CTR / (H)RTR A / B C / D	RPCT	ST	SC
2101 Esec 2005/2006 Dr.Tresky flip station West Bond	.315 / 8 .315 / 8 .625 / 16				
2102 Royce Instruments ASM Datacon / Viking Foton / Häcker / Hilbond Delvotec / Air-Vac Muehlbauer / Amadyne K&S6300/6900 Laurier DS x000 / K&S 6490 SEC	.315 / 8 .550 / 14 .625 / 16 .625 / 16 .625 / 16 .625 / 16 .750 / 19 1.25 / 32				
2102A1 Shinkawa	--				N/A
2102M2 Universal	--				
2112 Assembly Techn. ESC 2143 AMI ESC	.437 / 11.1 .437 / 11.1 .375 / 9.5 .375 / 9.5				N/A
2134 ASM 809	--				

2151-CT	CT Small / Large	RT Small / Large	IP/IPIR/IPNC IPRC/CH/PL	SEST	REST
N/A					
					
N/A					
					
N/A					
				N/A	N/A























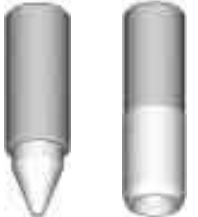







SHANK STYLES USED ON COMMON DIE ATTACH BONDERS

SHANK STYLE	SPECIFY L (inch/mm)	PCTR / FCTR / (H)CTR / (H)RTR A / B C / D	RPCT	ST	SC
2138 Shinkawa	--				
2138G Alphasem Easyline	--				
2141 - Dr. Tresky	625 / 16 .984 / 25				
2141M KME	--				N/A
GS Alphasem Swissline	--				
HG1.. / HG2.. Palomar (Hughes) HG1S / HG2S = Set Screw HG1S3 / HG2S3 = 3 Screws HG1P / HG2P = Press Fit HG1B / HG2B = Braze Fit ♦ 2101-.437 for HG1...500 ♦ 2101-.687 for HG1...750 ♦ 2102-.437 for HG2...500 ♦ 2102-.687 for HG2...750 To be ordered separately	.500 / 12.7 .750 / 19.0 Deep Access Deep Access	#10-32 UNF-2A 			

2151-CT	CT Small / Large	RT Small / Large	IP/IPIR/IPNC IPRC/CH/PL	SEST	REST
				N/A	N/A
					
					
N/A					
				N/A	N/A
					

SHANK STYLES USED ON COMMON DIE ATTACH BONDERS

SHANK STYLE	SPECIFY L (inch/mm)	PCTR / FCTR / (H)CTR / (H)RTR A / B C / D	RPCT	ST	SC
TSK Toshoko	--				
044C Quad APS-1	--				N/A
574 Ismeca 574A (notch on shank) Amicra (SDB1000 / ADB2000)	.551 / 14 .787 / 20 .984 / 25 1.18 / 30 1.18 / 30				
1059 (no Dowel Pin) 1059D (with Dowel Pin) MRSI 505	.688 / 17.5 .875 / 22.2				
MC ESEC Micron 2 ESEC Micron 5003	--				
MC26 (Fixed Inserted Shank) MC26A (with Spring Assembly) Available only with ★ ESEC Micron 2 ESEC Micron 5003	--		★	★	★













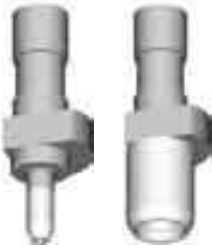

2151-CT	CT Small / Large	RT Small / Large	IP/IPIR/IPNC IPRC/CH/PL	SEST	REST
					
N/A					
					
					
N/A		N/A	N/A	N/A	N/A
	★ 	★ 		★ 	

SHANK STYLES USED ON COMMON DIE ATTACH BONDERS

SHANK STYLE	SPECIFY L (inch/mm)	PCTR / FCTR / (H)CTR / (H)RTR A / B C / D	RPCT	ST	SC
MC26AR (anti-rotation spring assembly) ESEC Micron 2 ESEC Micron 5003	--				N/A
DBH3 ESEC late 2006 ESEC 2007 ESEC 2008	--				N/A
VW Vacuum Wand	--				
GSM Universal	--				

Nozzles For Universal Machines

Other Various Shank Types and Tips Consult your nearest SPT office for details.					
--	--	--	--	--	--

2151-CT	CT Small / Large	RT Small / Large	IP/IPIR/IPNC IPRC/CH/PL	SEST	REST
N/A			N/A		
				N/A	N/A
N/A				N/A	N/A
				N/A	N/A