

DOUBLE CROSS PROTRUSION SINGLE POINT-TAB TOOL

7500 / 7600 STYLES

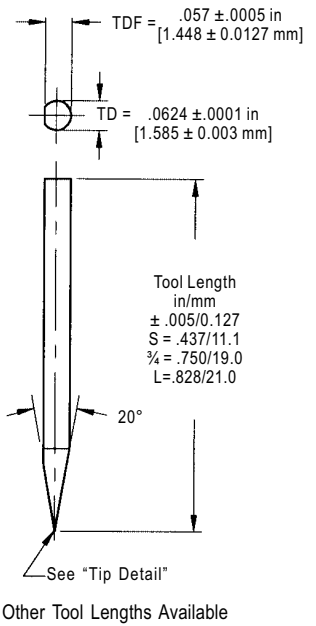

TIP DETAIL

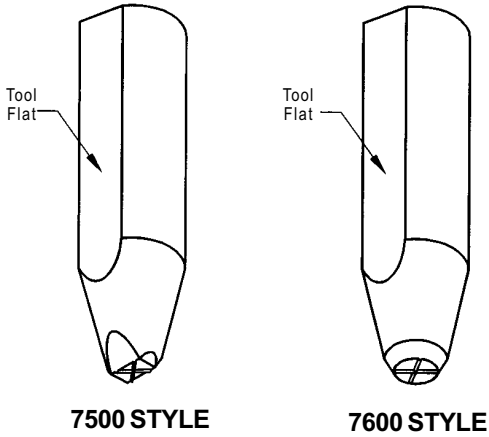
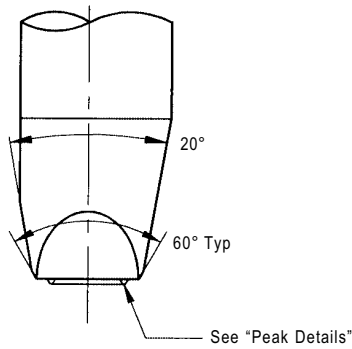

TIP DETAIL

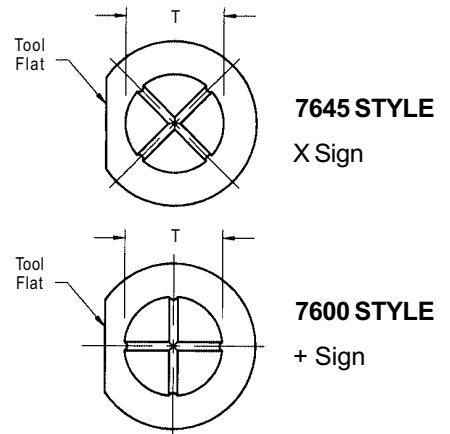
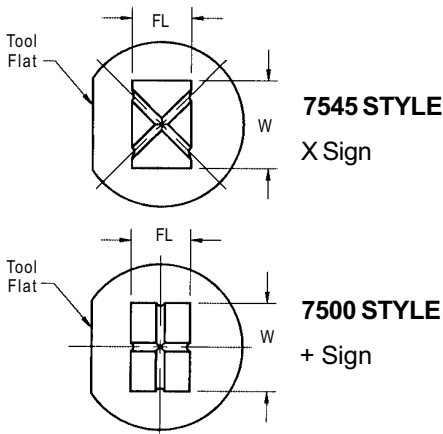
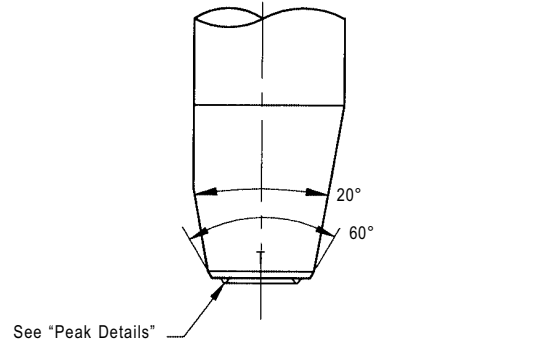

Peak DETAIL

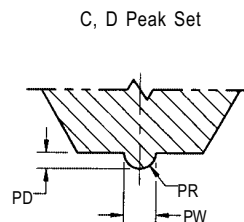
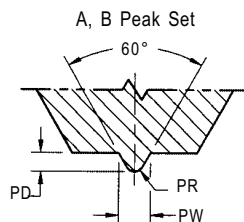

DOUBLE CROSS PROTRUSION SINGLE POINT-TAB TOOLS - GENERAL GUIDELINES ON HOW TO ORDER



DOUBLE CROSS PROTRUSION 7500/7600"

STYLE		MATERIAL	
7500 / 7600 7545 / 7645	Double Cross Protrusion	AZO*	Molded Ceramic (for high volume)
		DT	Diamond Tip
		C	Cermet composite for Gold Wire (recommended for Low Temperature bonding)
		TI	Titanium Carbide Composite for Gold Wire

TIP DETAILS		FOOT OPTIONS	
W/FL	Specify "W" and "FL"	M	Matte Finish
T	Specify "T"		

HOW TO ORDER	
SPECIFY	Style/Peak Set - Material - W/FL or T - Tool Length - Foot Option
EXAMPLE	7500A - AZO - 4025 - S - M 7545B - DT - 8060 - .375 - M 7645B - TI - 0060 - 3/4 - M

STANDARD PEAK DIMENSIONS				
Peak Set	Peak Shape	PW in / μm $\pm .0002/5$	PD in / μm $\pm .0001/3$	PR in / μm (Ref)
A	60° `v`	.0005 / 13	.0025 / 6	.0002 / 5
B	60° `v`	.0008 / 20	.0005 / 13	.0002 / 5
C	Radius	.0006 / 15	.0003 / 8	.0003 / 8
D	Radius	.0010 / 25	.0005 / 13	.0005 / 13

Include Peak Set call out after Tool Style name to indicate Groove dimensions.

STANDARD DIMENSIONS				
7500, 7545 Tool Style			7600, 7645 Tool Style	
W/FL	Foot Width W in / μm $\pm .0002/5$	Foot Length FL in / μm $\pm .0002/5$	T	Tip Diameter T in / μm $\pm .0002/5$
4035	.0040 / 102	.0035 / 89	0030	.0030 / 76
4040	.0040 / 102	.0040 / 102	0035	.0035 / 89
6035	.0060 / 152	.0035 / 89	0040	.0040 / 102
6040	.0060 / 152	.0040 / 102	0050	.0050 / 125
6050	.0060 / 152	.0050 / 125	0055	.0055 / 140
6060	.0060 / 152	.0060 / 152	0060	.0060 / 152
8040	.0080 / 203	.0040 / 102	0070	.0070 / 178
8050	.0080 / 203	.0050 / 125		
8060	.0080 / 203	.0060 / 152		
8070	.0080 / 203	.0070 / 178		